

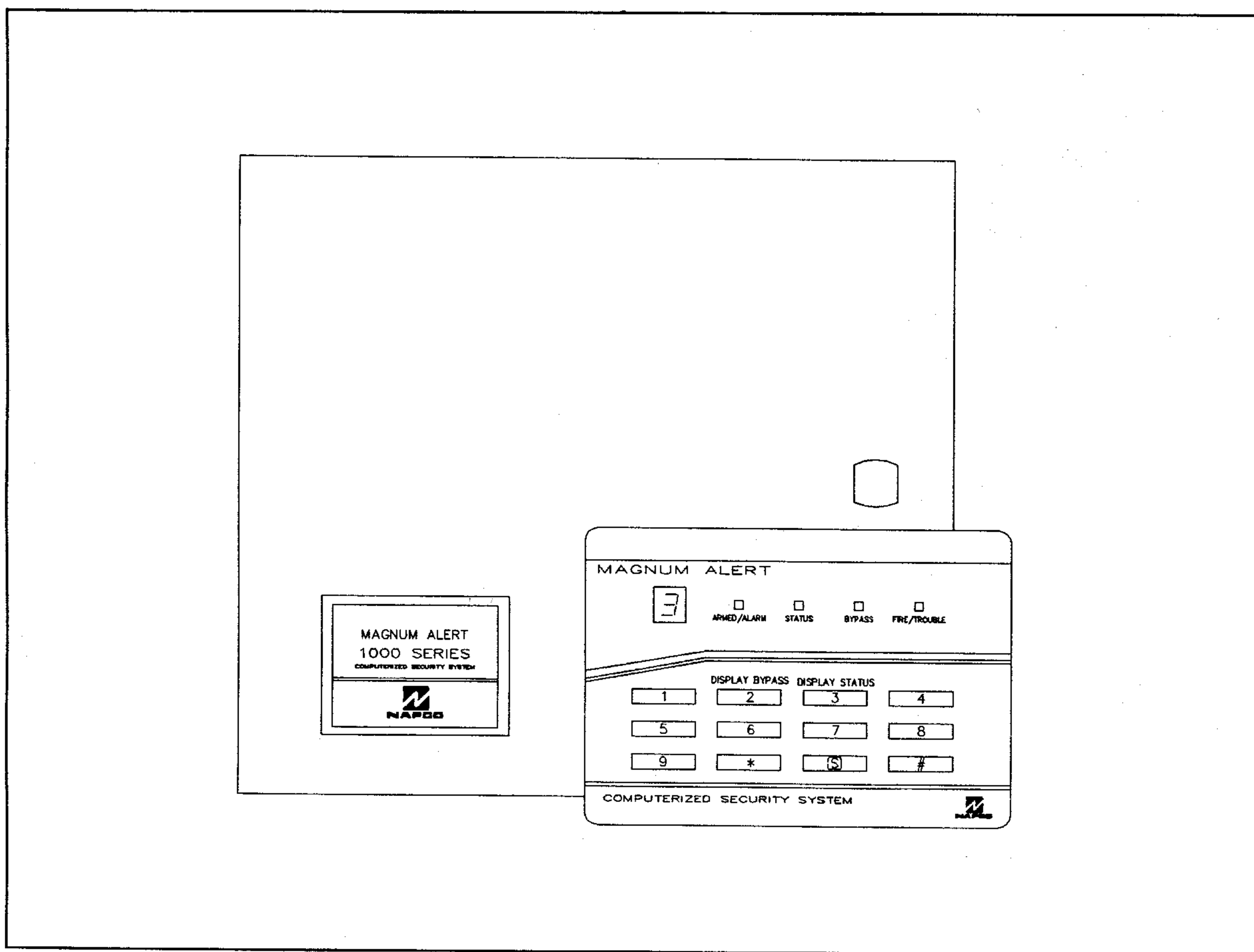

# INSTALLATION INSTRUCTIONS

## MAGNUM ALERT 1008LK/1008LKDL CONTROL PANEL/COMMUNICATOR



*UL Listed: Household Fire & Burglary Warning System Control Unit*

## Table of Contents

<i>Section</i>	<i>Page</i>
<b>1. INTRODUCTION</b> . . . . .	<b>3</b>
GENERAL DESCRIPTION . . . . .	3
FEATURES . . . . .	3
SPECIFICATIONS . . . . .	4
ORDERING INFORMATION . . . . .	4
UL CLASSIFICATION . . . . .	4
COMPATIBLE UL-LISTED DEVICES . . . . .	5
SUMMARY OF UL REQUIREMENTS . . . . .	5
<b>2. INSTALLATION</b> . . . . .	<b>6</b>
CONTROL-PANEL MOUNTING . . . . .	6
GROUNDING . . . . .	6
TAMPER SWITCHES . . . . .	6
KEYPAD WIRING . . . . .	6
TYPICAL FIRE INSTALLATION . . . . .	6
<b>3. GETTING UP AND RUNNING</b> . . . . .	<b>7</b>
POWER-UP SEQUENCE . . . . .	7
DEFAULT PROGRAM . . . . .	7
CENTRAL-STATION REPORTING . . . . .	7
USER KEYPAD PROGRAMMING . . . . .	7
TESTING THE SYSTEM . . . . .	8
<b>4. PROGRAMMING</b> . . . . .	<b>9</b>
KEYPAD PROGRAMMING . . . . .	9
PROGRAMMING SHEETS . . . . .	10
DOWNLOADING FROM A COMPUTER . . . . .	11
PROM PROGRAMMING . . . . .	11
GLOSSARY & PROGRAMMING DATA . . . . .	15
<b>5. WIRING DIAGRAM</b> . . . . .	<b>30</b>
WIRING LEGEND . . . . .	31

*INDEX STARTS ON PAGE 27*

*(SEE PAGE 5 FOR A SUMMARY OF CHANGES FROM PREVIOUS EDITION)*

**Napco Security Systems, Inc.**

**333 Bayview Avenue**

**Amityville, New York 11701**

**For Sales, Repairs and Technical Service, call Toll Free: (800) 645-9445**

# 1. INTRODUCTION

## GENERAL DESCRIPTION

The MAGNUM ALERT-1008LK and -1008LKDL are microcomputer-based eight-zone control panels with provisions for Ambush, Panic, a supervised Fire Zone and a variety of reporting features. The system is contained within a wall-mounted enclosure and includes an integral digital communicator and a power transformer.

The keypad allows the user to perform the following functions:

- arm and disarm the system,
- check the status of each zone,
- check which zones were violated after an alarm,
- selectively bypass one or more zones,
- display bypassed zones,
- cancel entry delay,
- send a Panic or Ambush alarm,
- enter or change arm/disarm codes,
- test the audible alarm circuit,
- test each zone for problems (Fault Find),
- test the telephone line while disarmed,
- reset Ac-Failure indication,
- bypass a Priority Zone with Bypass
- turn the Chime feature on/off, and
- program zone features and communicator information

Four LEDs, a display and a sounder on the keypad provide visual and audible system and individual zone status information. Most keys have secondary functions that are accessed by holding down the key until the sounder beeps, and are therefore termed "hold-down" functions. The following hold-down functions are provided:

Key [1]: Alarm Test

Key [2]: Display Bypassed Zones

Key [3]: Display Status

Key [4]: Instant Alarm (cancels entry delay)

Key [5]: Chime on/off

Key [6]: Communicator Confidence Test or Manual Download (see text)

Key [7]: Fault Find

Key [8]: Program

Key [9]: Reset (Ac-Fail indication; Day-Zone indication; Alarm-Memory display; Fire Zone; Fault-Find mode; Bypass Priority-with-Bypass; and Power-Up Delay)

Key [S]: Alarm History (indicates last alarmed zone(s))

The panels may be programmed in a variety of ways: (a) from the keypad, in its secondary Dealer-Program Mode of operation; (b) from a PROM (programmable read-only memory), which is itself programmed on an accessory programmer; or (c) from an IBM PC-compatible computer using Napco's PCD2000 Quickloader™ Software (MA1008LKDL only).

Designed for use with the PCI2000 Computer Interface Kit, the MA1008LKDL includes a modem to permit remote downloading/uploading over telephone lines or local downloading using a PCL2000 Local Download Cable.

## FEATURES

### Protection Zones

- Six end-of-line-resistor supervised zones.
- Two separately-programmable entry delays for Exit/Entry Zones.
- Burglary Zone options include:
  - Priority or Priority with Bypass
  - Selective or Group Bypassing
  - 24-Hour Protection
  - Day Zone Supervision
  - Auto Reset
  - Exit/Entry Delay 1; Exit/Entry Delay 2
  - Preprogrammed Auto Bypass (removable)
  - Optional 50mS or 7mS Loop Response (normally 750mS)
  - Programmable Abort Delay
- Separate supervised Fire Zone
- Keypad Panic Zone

### Alarm Outputs

- Timed Burglary and Fire Output: Programmable by zone and time
- Timed Fire Output: Fixed to Fire Zone, programmable for time
- Pulsing Bell Output: Fixed to Fire Zone, programmable for time
- NTO (No Timed Output) Lug

### Keypad Functions

- Keypad permits:
  - Arm/Disarm Code Selection of up to 5 user codes, up to 4 digits each
  - Digital Code Entry to arm and disarm system
  - Selective and Group Bypass Selection
  - Panic Zone Activation
  - Ambush Activation
  - Hold-Down Function Access
  - Resetting of various functions and conditions
  - Programming zone features and communicator options
- LEDs display:
  - Alarm State (armed/disarmed) (ARMED/ALARM)
  - Zone Status (STATUS) - one or more zones in trouble
  - Zones Bypassed - one or more zones removed
  - Fire Zone Status (FIRE/TROUBLE)
- Display indicates:
  - Zone(s) in alarm and alarm history
  - Zone(s) in trouble
  - Zone(s) bypassed
  - System Troubles
  - Programmed data entries (Dealer Program Mode)
- Sounder signals:
  - Entry Delay in Progress
  - Hold-Down Function Accessed

- Entry Door Opened while Disarmed (Chime)
- System Armed with a Zone in Trouble
- Day Zone in Trouble
- Fire Zone Alarm/Trouble
- Central-Station Ringback

#### Communicator Features

- Integral digital communicator with true dial-tone detection, double-pole line seizure and anti-jam.
- Programmable abort delay time.
- Rotary or TouchTone® dialing available. Rotary dialing available as backup to unsuccessful TouchTone dialing.
- Two telephone numbers and receiver/data formats can be accessed.
- Two-digit event codes and 4-digit subscriber codes programmable for those receivers accepting these formats.
- Central-Station Ringback.

#### Reporting Features

- Report on Alarm
- Opening and/or Closing Reporting by Individual User
- Opening Report After Alarm
- Day Zone Trouble; Fire Zone Trouble
- Ambush; Panic
- Test Timer; Reset Test Timer on Any Report
- Ac Failure; Low-Battery Report
- Force-Arm Report; Force-Arm/Status Report
- Control-Panel Restore Report; Zone-Restore Report
- Backup Reporting; Double Reporting; Split Reporting

#### Other Features

- Audible Bell-Test on Arming
- Power-Up in Last State
- Programmable Chime Duration
- Chime/Display Chime Mode
- No End-of-Line Resistor
- Watch Mode
- Sensor Watch™
- 2- or 4-Wire Smoke Detector Compatibility
- Electronic Dealer Lockout prevents unauthorized access.

#### SPECIFICATIONS

Operating Temperature: 0–49 °C (32–120 °F)

Input Power: 16Vac, Class 2 step-down transformer (TRF12)

Loop Voltage: 10–13Vdc

Loop Current: 2.8mA (normal resistance)

Loop Resistance: 300 ohms maximum series resistance

Alarm Output (Burg/Fire): *Commercial*, 12Vdc, 1.2A maximum; *Residential*, 10.9–12.5Vdc, 125mA max.\*

(Dry) Contact Ratings: 24Vdc, 2A (resistive)

Auxiliary Output: *Commercial*, 12Vdc regulated; *Residential*, 10.6–12.5Vdc\*

Combined Standby Current: (Remote Power + Aux. Output + Relay Output) 450mA maximum with standard

TRF12; 500mA maximum with optional TRF11

Remote Station,

Current: 25mA typical

Maximum Number: 5

Recommended Battery: Rechargeable, sealed lead-acid, 12Vdc, 4AH (RBAT4)

Standby Time: 6 hours at 350mA Combined Standby Current

Fuses,

Burglary/Fire Output: 3A, 1AG (F2)

Remote Power: 1A, 1AG (F3)

Battery: 5A, 1AG (F1) (Non-Replaceable)

Housing Dimensions: 12.6 x 12.6 x 3.6" (32 x 32 x 9.1cm) HxWxD

Shipping Weight: Approx. 15 lb (6.8kg)

\*If using PS3002 Power-Supply Module (optional), same specs as *Commercial* installations.

#### ORDERING INFORMATION

##### Equipment Supplied

MA1008LK/LKDL – Residential 8-zone (6 Burglary; 1 Fire; 1 Keypad Panic) 12-volt alarm control panel with integral communicator and TRF12 power transformer (1)

##### Optional Peripherals and Accessories

RP854 Traditional Remote 4-Wire Keypad  
 RP1054D Designer-Style 4-Wire Keypad  
 RP1000LCD Designer-Style Keypad with LCD display  
 RBAT4 Rechargeable Battery, 12Vdc, 4AH  
 RBAT4GS Rechargeable Battery, 12Vdc, 4AH  
 RBAT6 Rechargeable Battery, 12Vdc, 6AH  
 RBAT6GS Rechargeable Battery, 12Vdc, 6AH  
 RBAT-H1\* Dual Battery Harness (not for UL installations)  
 TRF8 Transformer, 16Vac, 14.4VA, Class 2 (UL Listed)  
 TRF11 Transformer, 16Vac, 40VA, Class 2 (UL Listed)  
 TRF12 Transformer, 16Vac, 19.2VA, Class 2 (UL Listed)  
 DH-1\* Diode Harness  
 EOL2.2K End-of-Line Resistor Assembly, 2.2k ohms  
 FT2200 End-of-Line Relay/Resistor Supervisory Module  
 PS3002 Power-Supply Module  
 GSM-400 Ground-Start Module  
 LOCK-8 Lock & Key Set  
 M278\* Line-Reversal Module  
 PCI2000 Quickloader Interface and Software  
 PCL2000 Quickloader Local Download Cable  
 TM900\* Timer Module  
 RPB-1 Surface Mounting Backplate for RP854  
 RPB-2 Double Gang Box for RP854  
 WL1 Wire with Lug Connector, 20"  
 PF173 Programming Record Sheets, 100/pad  
 PRO410M PROM Programmer  
 DD499 Partially-Programmed PROM  
 DD493BNK Blank PROM  
 \*UL-Listed Accessory

#### UL CLASSIFICATION

Household Fire and Burglary Warning System Control Unit. Combination Fire and Burglary (see *Compatible UL-Listed Devices*).

## COMPATIBLE UL-LISTED DEVICES (See Note below)

### Bells:

Ademco AD8-12, AD10-12

Amseco MBL-8/12V, -10/12V

Wheelock 34T-12R\* (Rated at 85dB for indoor household applications)

### Grade-A Bell:

Ademco AB-12, Bell in Box

### Smoke Detectors: (Residential Units Only)

#### 4-Wire:

BRK 1812, 2812TH; 1851B, 2851B, 2851BTH, each with B102 Base

ESL 445AT\*, 445C, 445CT, 445CR, 445CRT

Gentex 812, 812T, 812P, 812PT, 812PH; 8120, 8120T, 8120P, 8120PT, 8120PH

Hochiki SLG with YBC-RL4-RA Base

#### 2-Wire

BRK 1400\*, 2400\*, 2400TH\*, each with B101B Base; 1451\*, 2451\*, 2451TH\*, each with B401B Base

*Subtract total smoke-detector alarm current from available standby current.*

**\*Note:** Optional PS3002 Power-Supply Module required except where indicated by "\*\*"

## SUMMARY OF UL REQUIREMENTS

The following summarizes UL programming and wiring requirements.

- Recognized Limited-Energy Cable for initiating, indicating and supplementary circuits;
- Initiating loops supervised if longer than 3 feet;
- FT2200 End-of-Line Relay for Fire;
- Minimum alarm timeout of 4 minutes;
- Maximum exit time: 60 seconds; maximum entry time: 45 seconds;
- Do not program *Swinger Shutdown; Force Arming; Group Bypass; 7mS or 50mS Loop Response. Abort Delay* may not exceed 45 seconds.
- Automatic dialer may not dial a police-station number that has not been dedicated for such service;
- Battery Fuse F1 is not field serviceable. If F1 is open, return board to Napco for repair;
- System must be tested at least weekly under ac/battery and battery-only conditions;
- Replace the rechargeable battery at least every 5 years;
- If the battery is heavily discharged, replace it or have it tested by a qualified technician.
- Remote panic switches must be located in the same room as the control unit and keypad. Wiring may not pass through any barrier.
- For silent panic, connect only to UL-listed holdup devices.  
*In California:* CFM-listed for residential use. (Listing No. 7165-992:111.)

## CHANGES FROM PREVIOUS EDITION

The following changes have been made to this edition.

- Page 3: "System Troubles" added to Keypad (Display) Functions.
- Page 4: "TPS-2" deleted from Ordering Information.
- Page 7: "Keypad Tactile Beep (enabled)" added to Default Program.
- Page 8: "System Troubles" added.
- Page 14: "Enable Keypad Tactile Beep" (Location 181) added to Programming Sheet.
- Page 19: "Enable Keypad Tactile Beep" added to Glossary.
- Page 25: Fire-Zone Trouble text revised.
- Pages 27-27: Index updated.

## 2. INSTALLATION

### CONTROL-PANEL MOUNTING

Choose a mounting location accessible to (a) a continuously-powered ac source, (b) a cold-water-pipe ground ideally no further away than 10 feet, and (c) telephone lines (keep telephone wiring away from speaker wires). Remove appropriate knockouts for cables. Place the control panel at a convenient viewing height and mark the mounting holes.

A keypad should be located near the exit/entry door. If a keypad is to be mounted at the panel, remove the knockout on the enclosure door.

Up to 5 keypads may be connected if the longest cable run from the panel to the farthest keypad, whether daisy chained or home-run wired, is less than 1000 feet. See *Combined Standby Current* specifications. Each RP1054D keypad typically draws 40mA, however do not use more than 5 keypads.

### GROUNDING

Connect the control-panel grounding screw to a metal cold-water pipe. Do not use a gas pipe, plastic pipe or ac ground connections. Use at least 16-gauge wire. Make the run as short and direct as possible, without any sharp bends in the wire.

### TAMPER SWITCHES

Tamper switches may be installed to prevent opening of the enclosure door or removal of the cabinet from the wall. Ideally, tamper switches should be connected to a zone that is active at all times, thus it may be necessary to program that zone for *24-Hour Protection*. When used on a normally-open zone, normally-closed tamper switches (open when set) should be wired in parallel. On a normally-closed zone, install Napco TPS-2 normally-open tamper switches (closed when set) in series. There are two tamper-switch provisions in the cabinet:

1. To prevent cabinet removal from the wall, there are three mounting holes on the left side of the cabinet; another hole on the back that allows the switch button to contact the wall.
2. To prevent opening the cabinet door, there are three mounting holes on the right side of the cabinet. When mounted, the tamper-switch button should contact the inside of the door. Be sure to alert the user that opening the enclosure door will cause a tamper alarm.

### KEYPAD WIRING (Also see *Wiring Diagram*)

Connections to the keypad are summarized in Table 1. Avoid routing keypad wiring close to zone wiring.

**Note:** If using a soldering iron, avoid splashing solder onto keypad circuit board or components.

Keypad Wire Color	MA1008LK Terminal
Yellow	5
Green	6
Red	3
Black	4
White*	to N/O momentary remote-panic pushbutton switch(es)
White*	

**Table 1. Keypad wiring to control panel.**

*\*RP854 & RP1054D only:* Wire additional Panic Switches in parallel. Insulate *both* white wires if not used (a short will cause a panic alarm).

### TYPICAL FIRE INSTALLATION

At least one smoke detector should be installed directly outside each sleeping area. If there is more than one floor, additional smoke detectors should be installed on each level, including the basement. The living-area and basement smoke detectors should be installed near the stairway of the next upper level.

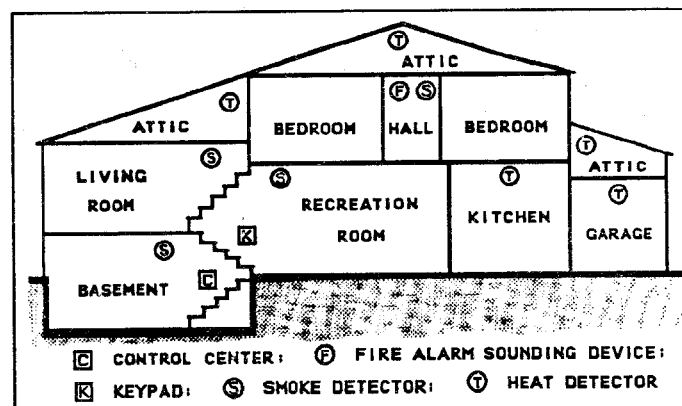

**Fig. 1. Typical fire installation.**

For increased protection, additional detectors should be installed in areas other than those required, such as dining rooms, individual bedrooms, furnace rooms, utility rooms and hallways. Heat detectors, rather than smoke detectors, are recommended in garages, attics, and kitchens due to conditions that may result in false alarms and improper operation. Large areas and areas with partitions, ceiling beams, doorways, and open joists will require additional detectors. Refer to NFPA Standard 74 (National Fire Protection Association, Batterymarch Park, Quincy, MA 02269) for additional information, including proper mounting methods.

### 3. GETTING UP AND RUNNING

#### POWER-UP SEQUENCE

1. Referring to the Wiring Diagram, (a) connect the keypad to Terminals 3–6 and (b) install end-of-line resistors (color code red/red/red) across each zone.
2. Connect an earth ground (cold-water pipe) to Terminal 10.
3. Connect the power transformer to Terminals 1 and 2 and plug the transformer into ac power.
4. Install the standby battery.
5. Check that the green STATUS LED on the keypad is lit.
6. Install loop wiring to zone terminals and relocate resistors to end of loops. Recheck green STATUS LED.
7. If reporting to a central station, connect a telephone connecting cord from Terminals 19–22 to the RJ31X jack, then see *CENTRAL-STATION REPORTING*, at right.

#### DEFAULT PROGRAM

The MA1008LK and MA1008LKDL will function as a local alarm control panel *right out of the box!* The following default program is entered at the factory. It is the installer's responsibility to add, change and/or delete features in accordance with these instructions to customize the system to the user's requirements and to conform to local codes.

- Arm/Disarm Code: 1,2,3 (User 1)
- User Program Code: 1,2,3,4,5,6
- Dealer Program Code: 4,5,6,7,8,9
- Exit/Entry (Entry Delay 1): Zone 1
- Entry Delay 1: 30 seconds
- Entry Delay 2: 30 seconds
- Exit Delay: 45 seconds
- Priority: Zones 1–6
- Selective Bypass: Zones 1–6
- 24-Hour Protection: Keypad Panic
- Auto Reset: Zones 1–6; Keypad Panic
- Swinger Shutdown: Zones 1–6
- Chime: Zone 1
- Chime Time: 2 seconds
- Burglary Output: Zones 1–6; Keypad Panic
- Burglary Timeout: 15 minutes
- Fire Timeout: 15 minutes
- Download With Answering Machine enabled
- Auto-Reset After Alarm Timeout enabled
- Power Up In Last State enabled
- Pulsing Fire Output enabled
- Reset Fire Zone enabled
- Keypad Tactile Beep enabled
- Keypad Panic enabled
- Communicator-Confidence Test enabled
- Alarm/Trouble Codes,
  - Zones 1–6: 31–36
  - Keypad Panic: 21
  - Fire: 11
  - Ambush: 22
  - Fire Trouble: 1F

- No Ac: F9
- Low Battery: F8
- Restore Codes,
  - Zones 1–6: E1–E6
  - Fire: E1
  - Fire Trouble: EF
  - No Ac: E9
  - Low Battery: E8
- Closing Codes, Users 1–4: C1–C4
- Opening Codes, Users 1–4: B1–B4
- Force-Arm Code: F

#### CENTRAL-STATION REPORTING

The following additional programming is required for central-station reporting.

- Report on Alarm
  - Subscriber ID (Account) Numbers, Groups 1 & 2\*
  - Receiver Format\*
  - Data Format\*
  - Telephone Number\*
- \*Obtained from central station.

**Note:** Remember, for optimum security, the following code must also be reprogrammed:

- User-1 Code (see *Programming User Codes*, below)
- (For other programming, see Section 4, *Dealer Keypad Programming* and the RP1054D programming aid illustrated in Fig. 2.)

#### USER KEYPAD PROGRAMMING

##### Programming User Codes

**Note:** The User Program Mode is disabled for the first three minutes after power-up to allow you to use the Dealer Program Code. To cancel the delay, hold down Key [9].

Up to five different Arm/Disarm Codes may be entered into the control panel using the keypad. User Code 5 may be programmed as a Service Code (see *User 5 Service Code*), a special user code intended for temporary or occasional use only.

To program a User Code,

1. Hold down Key [8] until the sounder beeps, then enter the User Program Code. (The default User Program Code is 1,2,3,4,5,6, but this code *must* be reprogrammed.) When the User Program Code has been entered, the first three LEDs on the keypad will flash and the sounder will beep rapidly, indicating the User Program Mode.
2. Now enter up to five codes using any combination of up to four digits (digits 1–9 only) as follows: press [S], [1], then any 4 digits = User 1's code\*  
[S], [2], then any 4 digits = User 2's code  
[S], [3], then any 4 digits = User 3's code  
[S], [4], then any 4 digits = User 4's code  
[S], [5], then any 4 digits = User 5's code\*\*  
\*Default User-1 Code 1,2,3 must be changed.  
\*\*May be programmed as *Service* or *Arm-Only* Code.
3. To exit User Program Mode, press [S] *twice*.

The numbers selected are the only codes recognized by the system. Each user should be assigned his own dis-

similar code and cautioned against divulging that code to anyone else. Thus, should it become necessary to remove a user from the system, that one code may be voided without affecting other codes, and that user would then be prevented from entry.

### Changing or Voiding a Code

To change any User's Code, refer to *Programming User Codes* and simply change the 4-digit combination. Thus, to change User 3's code, for example:

1. Hold down Key [8] until the sounder beeps.
2. Enter the User Program Code (LEDs flash; sounder beeps).
3. Press [S], [3], then 4 new digits = User 3's new code.
4. Press [S] twice to exit User Program Mode.

Similarly, User 3's code may be voided by not entering a 4-digit combination. Thus, to void User 3's code:

1. Hold down Key [8] until the sounder beeps.
2. Enter the User Program Code (LEDs flash; sounder beeps).
3. Press [S], then [3] = User 3's code erased.
4. Press [S] twice to exit User Program Mode.

### System Troubles

System troubles, coded as follows, display numerically at the keypad in addition to the conventional flashing ARMED, STATUS and BYPASS LEDs. The indication may be temporarily reset by holding down Reset Key [9] in order to check zone status and/or arm the system.

**"1" - Ac Failure.** Indicates loss of ac power. The Ac-Failure indication will clear when ac power is restored.

**"2" - Low Battery.** Displays when battery terminal voltage drops below 11.5 volts, nominally. The system trouble

display will be cleared and a restore reported when (a) the battery terminal voltage has returned to its specified restored level and (b) the keypad is reset using Hold-Down Function 9.

**"3" - Failure to Communicate.** Indicates an unsuccessful transmission to the central station. If the panel is armed, disarm. Hold down Key [9] to reset the keypad, then hold down Key [6] to test the phone lines. If the test is successful, the display will clear; otherwise it will return, indicating a need for service. A successful communication followed by a Hold-Down [9] Reset will also clear the display.

**"7" - Auto-Download Failure.** Indicates failure of a Function-6 Auto-Download. Reset the display by holding down Key [9], then try again to auto-download the program.

### Arming & Disarming the System

When a User Code is entered into the keypad, the red ARMED/ALARM LED will either come on, indicating that the panel is armed; or go off, indicating that the panel is disarmed. A "P" on the display with a steady sounder indicates an attempt to arm with a Priority Zone in trouble; re-enter the code, then secure the zone. If a wrong code is entered, the system will fail to respond. Wait at least 2 seconds before attempting to re-enter a code.

### Alarm Reset

Disarm the panel to silence a sounding device.

### TESTING THE SYSTEM

After installation is completed, test the system as follows. Call the central station to inform them of the test. Initiate an alarm, preferably on a zone that activates a steady output. Verify proper signalling, then call the central station to confirm their receipt of a good transmission.



## 4. PROGRAMMING

### KEYPAD PROGRAMMING

Keypad Programming may be divided into two sub-groups: User Program Mode and Dealer Program Mode. *USER KEYPAD PROGRAMMING* is limited to user codes. In the Dealer Program Mode, the keypad provides full programming capabilities.

#### Dealer Keypad Programming.

Set the keypad to the Dealer Program Mode: Hold down Key [8] until a beep sounds, then enter the Dealer Program Code. (The default Dealer Program Code is 4,5,6,7,8,9, but this code *must* be reprogrammed to preserve system security. See Glossary and the programming example, which follows.) The center segment of the numeric display will light to indicate the Dealer Program Mode.

**Note:** The Dealer Program Mode cannot be accessed while the panel is armed or communicating *except* during the first three minutes after power-up. See *Power-Up Delay* in Glossary.

Set the location to be programmed by pressing Key [S] (the three horizontal segments of the display and the green LED will light), followed by the location number. Each location must be entered as a three-digit number, that is, 001, 020, 157, etc. Notice that as each of the three digits is entered, the three display segments extinguish in succession from bottom to top. When the last digit is entered, the yellow LED will light and the display will show the data (if any) programmed in that location.

At this point, several numeric keys will take on new functions (see Fig. 2). Note first, however, that the programming sheet is arranged in blocks. In general, each block contains two adjacent locations, but they may contain four locations (e.g., Subscriber IDs); six locations (e.g., User and Dealer Program Codes); or as many as 18 locations (Telephone Numbers). The functions of the following keys are reassigned to provide improved mobility around the programming sheet.

**Keys [1] or [6] (Prior Location) and [2] or [3] (Next**

**Location)** - Change the location. Use Key [1] or [6] to move down to the next lower location, or Key [2] or [3] to move up to the next higher location. Whenever a new location is entered, a beep will sound.

**Keys [4] (Data Up) and [7] (Data Down)** - select the data for the chosen location: numbers 1-9, 0, and letters B, C, D, E, and F, as will be indicated in the display. Key [4] sequences data values in ascending order; Key [7], in descending order.

**Key [5] (Clear)** - clears data from the selected location (display will go blank).

**Key [8] (Exit)** - exits the Dealer Program Mode. Hold down until the beep sounds, then enter the Dealer Program Code within 10 seconds to exit.

**Key [S] (Set)** - sets the location to be programmed. After pressing Key [S], enter a three-digit location number.

To exit the Dealer Program Mode, hold down Key [8] until the beep sounds; all four LEDs will light. Within 10 seconds, enter the Dealer Program Code; the LEDs will go out. (If the LEDs go out before your code is entered, repeat this procedure.)

**Caution:** Before exiting the Dealer Program Mode, be sure that Location 083 contains the data shown in Table 2. If the control panel comes up armed on power-up, you have three minutes to access the Dealer Program Mode. Hold down Key [8] for two seconds, then enter your Dealer Program Code. By checking Location 083, you can prevent accidental erasures of required data from going undetected. (If invalid data reside in Location 083, a non-existent fire trouble and/or loss of keypad functions may result. If you encounter this problem and need assistance, call Napco's Technical Service Department (toll free) at (800) 645-9445.

Disarmed	Armed
5	7, D or F

Table 2. Valid data for Location 083.

**Example 1.** Reprogram the existing (default) Dealer Program Code to 8,1,5,4,8,7.

1. Hold down Key [8] until the beep sounds.
2. Enter the existing (default) Dealer Program Code, 4,5,6,7,8,9. The center segment of the display will light.
3. Set Location 244, the first location of the Dealer Program Code block, as follows: (a) Press Key [S] (the three horizontal display segments and green LED will light); (b) press [2],[4],[4] (the yellow LED will come on and the display will indicate the first digit of the existing code, "4").
4. Program the first digit of the *new* Dealer Program Code as follows: Press Key [4] (Data Up) repeatedly until an "8" is displayed.
5. Press Key [2] (Next Location) once to advance to Location 245, the second digit of the code. A "5" (the second digit of the default code) will be displayed. To program the second digit of the *new* code press Key [5] (Clear), then press Key [4] (Data Up) once - a "1" will be displayed.
6. Press Key [2] (Next Location) once again to advance to the third location (246) of the code. Using Key [7] (Data Down), replace the "6" with a "5".
7. Repeat this procedure, using Key [2] to advance locations and Keys [4] and [7] to select data, until the entire code has been reprogrammed. To check the code, press Key [1] (Prior Location) five times to return to Location 244, then press Key [2] to step through each location, noting the data displayed.
8. To exit the Dealer Program Mode, hold down Key [8] until the beep sounds, then enter the *new* Dealer Program Code within 10 seconds. This will confirm operation of the new code.

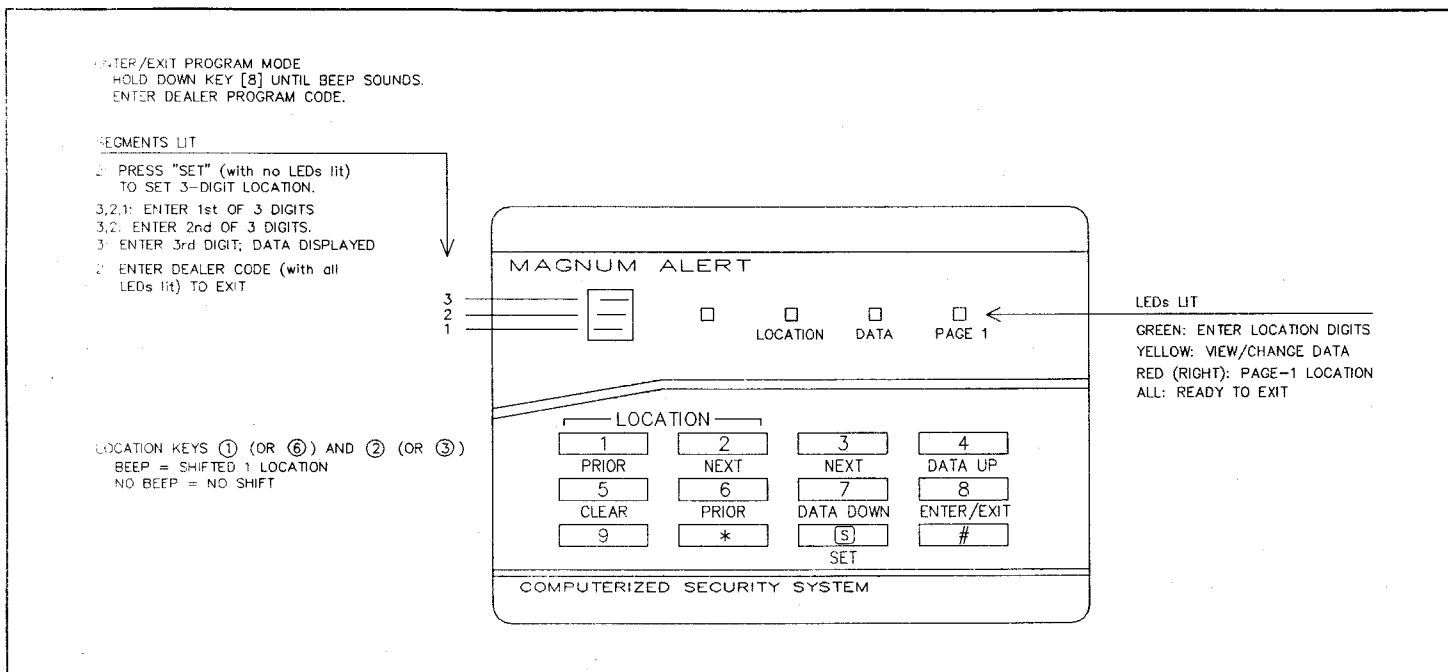

Fig. 2. Keypad functions in Dealer Program Mode (RP1054D Keypad shown).

### PROGRAMMING SHEETS.

Programming Sheets similar to those which follow are completed when planning system features and communicator information for the particular installation. These sheets should be retained for future reference. The Glossary contains information and instructions for programming each feature.

### General Programming Steps

1. Contact the central station to confirm receiver format, data format, event codes, subscriber numbers and telephone number(s). Two receiver descriptions and telephone numbers, and up to 4 Subscriber Identification Numbers may be required.
2. Fill out the Programming Record Sheets by circling the numbers representing the zone features or system features to be programmed. Referring to the programming sheets and the accompanying table, note that each program location is assigned data values (1,2,4,8) such that adding any combination will produce a unique total (entry). Also note that because the entry can be only one character, the two-digit totals greater than 9 are replaced by zero and letters B through F, as shown. Check the Glossary for guidance in selecting "data" entries.

3. To program the subscriber PROM, follow the instructions furnished with the programmer. While programming, remember to keep the address page number in mind, and be sure that the position of the PAGE switch (PRO410/410M) is set accordingly. **Note:** If using the Napco PRO410/410M programmer, before attempting to program either page, be sure that all data in programmer memory are erased (press [ERASE], then [EXECUTE]).
4. Program the entries (data totals from Programming Record Sheets in Step 2) into the respective locations. The display will show the entry numerically, but will display "0" for the number 10, and letters "B", "C", "D", "E", and "F" for the numbers 11 through 15, respectively. To program a 10, enter [0]. To program 11 through 15, enter [B] through [F] respectively. If using the Napco PRO410/410M programmer to program a PROM, use the [PLUS] key to enter any two or more digits that add up to the desired entry. To program 13, for example, enter either [d] or [8] [PLUS] [5], or [8] [PLUS] [4] [PLUS] [1], etc. Similarly, to add to an existing PROM location, first press the [PLUS] key, then the complementary digit, otherwise the digit entered will *replace* the digit in memory. Refer to the PRO410/410M instructions for further programming information.

*Example 2.* Program Zones 1-6 to report on alarm. Referring to the Communicator Information section of the Programming Sheet, *Report on Alarm* is contained in Locations 166 and 167. Circle data values for Zones 1-6.

	Zone 1	Zone 2	Zone 3	Zone 4	Zone 5	Zone 6		K/P	
Report on Alarm	166	166	166	166	167	167	167	167	location
	①	②	④	⑧	①	②		8	data

Add the data values for Location 166:  $1 + 2 + 4 + 8 = 15$ . From Table 3, 15 is programmed as an "F". Now add the data values for Location 167:  $1 + 2 = 3$ . From Table 3, enter a "3" in Location 167.

LOCATION XXX				ENTRY
				blank
(1)				1
	(2)			2
(1)	(2)			3
		(4)		4
(1)		(4)		5
	(2)	(4)		6
(1)	(2)	(4)		7
			(8)	8
(1)			(8)	9
	(2)		(8)	0 (10)
(1)	(2)		(8)	B (11)
		(4)	(8)	C (12)
(1)		(4)	(8)	D (13)
	(2)	(4)	(8)	E (14)
(1)	(2)	(4)	(8)	F (15)

Table 3. Determining data entry for a location. Numbers in parentheses indicate selected zones or features. (See Programming Sheet.)

#### DOWNLOADING FROM A COMPUTER USING NAPCO SOFTWARE AND INTERFACE.

##### Local Downloading

Data may be locally downloaded with the use of a PCL2000 Local Download Cable, which is supplied with the PCI2000 interface. Wiring information and instructions for local downloading are included with the PCI2000.

##### Remote Downloading

Data may be remotely downloaded to the panel via telephone lines using an IBM PC-compatible computer with Napco PCD2000 software and PCI2000 interface. On-screen prompting and the extensive use of help menus simplify programming, and an error-checking mode locates omissions and incompatible data to reduce the possibility of mistakes. Remote downloading requires (a) a modem compatible with the PCI2000 and (b) PCD2000 software Version 2.C or higher. **Note:** Remote downloading may be disabled through programming and *must* be disabled in UL installations.

A program may be downloaded remotely using either of the following procedures.

**Callback Method.** This method is used to download to an unattended panel. The MA1008LKDL will accommodate an answering machine at the site if line seizure is used on the house phones. Program a "1" in Location 082 (*Enable Download with Answering Machine*). Refer to the instructions furnished with the PCD2000 for details. **Note:** The number of rings programmed into the panel must exceed that of the answering machine.

**Function-6 Method.** Call the central station from the site to request a *Manual Download*. During this procedure, voice contact will be lost, therefore both the installer and the computer operator should be familiar with the operation. When a high-pitched tone is heard at the site phone, arm the panel, disarm, then access Hold-Down Function 6 (*Manual Download*); the site phone will go dead. Hang up the phone and wait for a call from the central station confirming a successful download.

#### PROM PROGRAMMING

A DD499 PROM may be programmed using a PRO410 or PRO410M Programmer. See *General Programming Steps* and the manual furnished with the programmer for operating instructions, and also the Programming Record Sheets that follow. PROM programming may be used to program all features except the Dealer Program Code (Locations 244-249) and User Arm/Disarm Codes.

#### Transferring Memory from a DD499 PROM.

Data programmed in the PROM are saved in memory as follows.

1. At the control panel, with ac and battery power *off*, insert the programmed PROM into the MEMORY CHIP socket. Align the dot on the PROM with the dot on the circuit board.
2. Apply ac power. Enter the Dealer Program Mode: Hold down Key [8] until the function beep sounds, then enter the Dealer Program Code.
3. Exit the Dealer Program Mode: Hold down Key [8] until the function beep sounds, then enter the Dealer Program Code.
4. Wait about 10 seconds. Remove both ac and battery power, remove the PROM from the socket, then power up normally.

# PROGRAMMING RECORD SHEET FOR THE MA1008LK & MA1008LKDL

Communicator Features – Default programming shown in parentheses.

	GROUP 1								GROUP 2								
	ZONE								AUX	FIR	DAY	TST	NO	LOW			
	1	2	3	4	5	6	K/P	8	FIR	AMB	TBL	TBL	TMR	AC	BAT		
REPORT ON ALARM	166								167								
CONTROL-PANEL RESTORE (SEE NOTE 1)	170								171								
ZONE RESTORE (SEE NOTE 1)	184								185								

ALARM/TROUBLE CODES	Single Digit	000	002	004	006	008	010	014	016	018	020	022	024	026	028
		(3)	(3)	(3)	(3)	(3)	(3)	(2)	(1)	(2)	(1)			(F)	(F)
	Extended or Two Digit	001	003	005	007	009	011	015	017	019	021	023	025	027	029
		(1)	(2)	(3)	(4)	(5)	(6)	(1)	(1)	(2)	(F)			(9)	(8)
RESTORE CODES	Single Digit	040	042	044	046	048	050	056	058	060	062	064	066	068	
		(E)	(E)	(E)	(E)	(E)	(E)	(E)	(E)	(E)	(E)	(E)	(E)	(E)	
	Extended or Two Digit	041	043	045	047	049	051	057	059	061	063	065	067	069	
		(1)	(2)	(3)	(4)	(5)	(6)	(1)	(F)	(F)	(F)	(F)	(9)	(8)	

	CLOSING USER				FORCE ARM	OPENING USER			
	1	2	3	4		1	2	3	4
Single Digit	030	032	034	036	038	070	072	074	076
	(C)	(C)	(C)	(C)	(F)	(B)	(B)	(B)	(B)
Extended or Two Digit	031	033	035	037	039	071	073	075	077
	(1)	(2)	(3)	(4)	(SEE NOTE 2)	(1)	(2)	(3)	(4)
Select User(s) Closing	174				Select User(s) Opening	176			
	1	2	4	8		1	2	4	8

	ALARM/RESTORE ID (SEE NOTE 3)				OPENING/CLOSING ID (SEE NOTE 4)							
	GROUP 1		GROUP 2									
Telephone 1	100	101	102	103	104	105	106	107	108	109	110	111
Telephone 2	132	133	134	135	136	137	138	139	140	141	142	143

	FORMAT RCVR DATA		PRE DLY	ACC NO.	D/T DET	TELEPHONE NUMBER 1																						
	1	2				114	115	116	117	118	119	120	121	122	123	124	125	126	127	128	129	130	131					
Telephone 1	112	113				(E)																						
Telephone 2	144	145				TELEPHONE NUMBER 2																						
						146	147	148	149	150	151	152	153	154	155	156	157	158	159	160	161	162	163					
						(E)																						
			# OF RINGS	CALLBACK TELEPHONE NUMBER																								
			269	270	271	272	273	274	275	276	277	278	279	280	281	282	283	284	285									
			013	014	015	016	017	018	019	020	021	022	023	024	025	026	027	028	029									

<-PROM PAGE-1 LOCATIONS

ENTRY	RECEIVER FORMAT
Blank	ADEMCO, SILENT KNIGHT SLOW
1	SESCOA, VERTEX, DCI, FRANKLIN (SEE NOTE 5)
2	RADIONICS FAST (SEE NOTE 5)
3	SILENT KNIGHT FAST
4	RADIONICS, DCI, FRANKLIN SLOW (SEE NOTE 5)
5	UNIVERSAL HI-SPEED
6	(RESERVED)
7	RADIONICS BFSK (SEE NOTE 5)
8	FOR 2300Hz HANDSHAKE, ADD AN "8" TO THIS LOCATION

ENTRY	DATA FORMAT
Blank	EXTENDED OR SINGLE DIGIT
1	SINGLE DIGIT
2	TWO DIGIT (OR 4/2)
4	SUM CHECK

- NOTES:
- 1 IF PROGRAMMING ZONE RESTORE, ALSO PROGRAM CONTROL-PANEL RESTORE.
  - 2 TWO-DIGIT FORMAT ONLY.
  - 3 GROUP-2 CODES MUST BE ENTERED, EVEN IF THEY ARE THE SAME AS GROUP-1 CODES.
  - 4 MUST BE PROGRAMMED IF OPENING/CLOSING CODES ARE PROGRAMMED.
  - 5 THESE FORMATS TYPICALLY USE A 2300Hz HANDSHAKE; ADD AN "8" TO THIS ENTRY.

CUSTOMER: \_\_\_\_\_  
 ADDRESS: \_\_\_\_\_  
 ACCOUNT NO. \_\_\_\_\_  
 TEL. \_\_\_\_\_  
 DATE: \_\_\_\_\_

# PROGRAMMING RECORD SHEET FOR THE MA1008LK & MA1008LKDL

**Zone Features – Default programming shown in parentheses.**

ZONE FEATURES	GROUP 1							GROUP 2						
	ZONE							AUX	FIR	DAY	TST	NO	LOW	
	1	2	3	4	5	6	K/P	FIR	AMB	TBL	TBL	TMR	AC	BAT
SWINGER SHUTDOWN	084							085						
	(1)	(2)	(4)	(8)	(1)	(2)	(8)							
NO END-OF-LINE RESISTOR	086							087						
	1	2	4	8	1	2								
CHIME ZONE	088							089						
	(1)	2	4	8	1	2								
NEVER ARM	090							091						
	1	2	4	8	1	2								
PIR ZONE	092							093						
	1	2	4	8	1	2								
UNTIMED OUTPUT (NTO LUG E15)	096							097						
	1	2	4	8	1	2	8	1	2	4	8	1	2	4
ENABLE KEYPAD SOUNDER ON ALARM	164							165						
	1	2	4	8	1	2	8							
DAY ZONE	186							187						
	1	2	4	8	1	2								
PRIORITY ZONE WITH BYPASS (SEE NOTE 1)	188							189						
	1	2	4	8	1	2								
PRIORITY ZONE	190							191						
	(1)	(2)	(4)	(8)	(1)	(2)								
REMOVE AUTO-BYPASS (SEE NOTE 1)	192							193						
	1	2	4	8	1	2								
SELECTIVE BYPASS	194							195						
	(1)	(2)	(4)	(8)	(1)	(2)								
GROUP BYPASS	196							197						
	1	2	4	8	1	2								
24-HOUR PROTECTION	198							199						
	1	2	4	8	1	2	(8)							
AUTO-RESET	200							201						
	(1)	(2)	(4)	(8)	(1)	(2)	(8)							
EXIT/ENTRY ZONE (ENTRY DELAY 1)	202							203						
	(1)	2	4	8	1	2								
EXIT/ENTRY ZONE (ENTRY DELAY 2)	204							205						
	1	2	4	8	1	2								
EXIT/ENTRY FOLLOWER	206							207						
	1	2	4	8	1	2								
ABORT DELAY	208							209						
	1	2	4	8	1	2								
BURGLARY OUTPUT	210							211						
	(1)	(2)	(4)	(8)	(1)	(2)	(8)							
7ms LOOP RESPONSE (SEE NOTE 2)	214							215						
	1	2	4	8	1	2								
50ms LOOP RESPONSE (SEE NOTE 2)	216							217						
	1	2	4	8	1	2								

ENTRY TOTAL:	blank	1	2	3	4	5	6	7	8	9	10	11	12	13	14	15
PROGRAMMER DISPLAYS:	.	1	2	3	4	5	6	7	8	9	0	B	C	D	E	F

SEE NOTE 3

SEE NOTE 4

NOTES: (1) If programming PRIORITY ZONE WITH BYPASS, do not program REMOVE AUTO BYPASS. (2) If neither 7ms nor 50ms LOOP RESPONSE is programmed, loop response will be 750ms. (3) • (dot) or blank for no entry. (4) To conform with Telephone Company convention, program zeros in Telephone Numbers, Alarm Codes and Subscriber ID Numbers as an entry total of 10. (Press DATA UP button until "0" is displayed; in PRO410, press Key [0].)

# PROGRAMMING RECORD SHEET FOR THE MA1008LK & MA1008LKDL

Codes, System Features & Timeouts – Default programming shown in parentheses.

## KEYPAD CODES (DO NOT ENTER ZEROS)

AMBUSH	USER PROGRAM CODE	DEALER PROGRAM CODE
236 237	238 239 240 241 242 243	244 245 246 247 248 249
	(1) (2) (3) (4) (5) (6)	(4) (5) (6) (7) (8) (9)

NOTE: THE DEALER PROGRAM CODE MUST NOT START WITH THE SAME NUMBERS AS THE USER PROGRAM CODE.

## SYSTEM FEATURES

INSTRUCTIONS: FOR EACH LOCATION: (1) CIRCLE NUMBERS FOR FEATURES DESIRED. (2) PLACE SUM OF CIRCLED NUMBERS IN "ENTRY" BOX.  
 WARNING: DO NOT ATTEMPT TO PROGRAM "RESERVED" LOCATIONS AS IMPROPER OPERATION MAY RESULT.

LOCATION 078	ENTRY	---
DISPLAY DAY ZONES AFTER RESET	1	
FAILURE TO COMMUNICATE ON NTO LUG	2	
USER 5 ARM ONLY	4	
USER 5 REPORT AS USER 1	8	

LOCATION 082	ENTRY	---
ENABLE DOWNLOAD W/ANSWERING MACH.	(1)	
REMOTE STATUS LED ON NTO LUG	2	
(RESERVED)		
(RESERVED)		

LOCATION 181	ENTRY	---
PULSING FIRE OUTPUT	(1)	
RESET FIRE ZONE	(2)	
ENABLE KEYPAD TACTILE BEEP	(4)	
RESET TEST TIMER ON REPORT	8	

LOCATION 079	ENTRY	---
USER 5 SERVICE CODE	1	
DISABLE DAY-ZONE REPORT	2	
(RESERVED)		
(RESERVED)		

LOCATION 178	ENTRY	---
TOUCHTONE(R) DIALING	1	
TOUCHTONE(R) WITH ROTARY BACKUP	2	
BACKUP REPORTING	4	
DOUBLE REPORTING	8	

LOCATION 182	ENTRY	---
DISABLE FAULT FIND	1	
ENABLE KEYPAD PANIC	(2)	
ENABLE COMMUNICATOR CONF. TEST	(4)	
DISABLE BELL TEST	8	

LOCATION 080	ENTRY	---
DIRECT KEYPAD PANIC TO AMBUSH	1	
(RESERVED)		
DISABLE CALLBACK DOWNLOAD	4	
DISABLE FUNCTION-6 DOWNLOAD	8	

LOCATION 179	ENTRY	---
OPENING REPORT AFTER ALARM	1	
FORCE ARM	2	
STATUS REPORT	4	
SPLIT REPORTING	8	

LOCATION 183	ENTRY	---
DISPLAY ANY BYPASS	1	
NO OPNG REPT AFTER ALRM ON ZONE 6	2	
INCL MAHL BYP IN FORCE-ARM/STATUS	4	
(RESERVED)		

LOCATION 081	ENTRY	---
WA'CH ON WITH GROUP BYPASS	1	
CHIME ON WITH GROUP BYPASS	2	
DISPLAY CHIME ZONES	4	
DISABLE DISPLAY BYPASS	8	

LOCATION 180	ENTRY	---
AUDIBLE TEST ON ARMING	1	
AUTO-RESET AFTER ALARM TIMEOUT	(2)	
POWER UP IN LAST STATE	(4)	
SOUNDER OUTPUT ON LUG E4	8	

## Times & Timeouts

TIME EXAMPLES		
TIME	1st BOX	2nd BOX
5	5	NONE
10	0	NONE
15	F	NONE
30	E	1
45	d	2
60	C	3

094	095	SENSOR WATCH
		(hours)
250	251	TEST-TIMER
		OFFSET (hours)

DELAY TIME		
218	219	EXIT DELAY
		(D, 2) (seconds)
220	221	ENTRY DELAY 1
		(E, 1) (seconds)
222	223	ENTRY DELAY 2
		(E, 1) (seconds)
232	233	ABORT DELAY
		(seconds)

TIMEOUT		
224	225	BURG OUT TIMEOUT
		(F, ) (minutes)
228	229	FIRE TIMEOUT
		(F, ) (minutes)
230	231	CHIME TIME
		(8, ) (1/4 seconds)

↑  
Example: For 2 seconds, enter "8" in loc. 230

ENTRY TOTAL:	blank	1	2	3	4	5	6	7	8	9	10	11	12	13	14	15
PROGRAMMER DISPLAYS:	•	1	2	3	4	5	6	7	8	9	0	B	C	D	E	F

SEE NOTE 1

SEE NOTE 2

NOTE: (1) • (dot) or blank for no entry. (2) To conform with Telephone Company convention, program zeros in Telephone Numbers, Alarm Codes and Subscriber ID Numbers as an entry total of 10. (Press DATA UP button until "0" is displayed; in PRO410, press Key [0].)

## GLOSSARY & PROGRAMMING DATA

### Abort Delay (Locations 208, 209; 232, 233)

A delay period that allows cancellation of the central-station report. This is done by disarming the panel within the delay period. Program Locations 208-209 for zone selection; Locations 232, 233 for delay time (see *Time Selection*). The NTO Lug E15 will be subject to the abort delay if *Untimed Output* and *Abort Delay* are programmed for the same zone.

**Note:** If *Abort Delay* is selected for a 24-Hour Zone or a Zone-Restore Zone, the cause of the alarm must be corrected before disarming the panel.

### Ac-Failure Reporting (Locations 169; 173)

If ac is removed from the panel, the first three LEDs will flash slowly (while armed or disarmed). If disarmed, holding down Key [9] will reset the indication for about three minutes to permit arming. However, the failure indication will return within a few minutes, whether armed or disarmed, unless ac power is restored. If programmed for *Report on Alarm*, the report will be delayed for 1 hour. Restores report immediately.

### Access Number for Outside Line (Locations 115, 147)

Some subscribers will have a telephone system that requires one digit to access an outside line before the telephone number can be dialed. Also, the first dial tone encountered (prior to the access number) may have a frequency that is different from that of the accessed dial tone (440Hz). One or more 4-second *Pre-Dial Delay* "D"s may be entered before the access number instead of a dial tone with frequency "E". See *Pre-Dial Delay*.

If your subscriber's system uses an access number:

1. Contact the telephone-equipment supplier to find out if a dial tone other than 440Hz is received prior to dialing the access number. If the communicator must delay before dialing the access number instead of attempting to recognize the dial tone, find out how many 4-second delays must be programmed.
2. For Telephone 1,
  - a. Enter the *Dial-Tone Detection* "E" or *Pre-Dial Delay* "D" in Location 114. Enter any extra "D"s that may be required starting in Location 115.
  - b. Enter the access number digit in Location 115, or the first available location thereafter.
  - c. Starting in the first available location after the access number, enter any *Pre-Dial Delay* "D"s needed before the second dial tone; the *Dial-Tone Detection* "E" for the second dial-tone frequency; then the telephone number.

3. If Telephone 2 is used, repeat Step 2 starting in Location 146. (See *Backup Reporting*; *Double Reporting*; and *Split Reporting*.) Also see *Dial-Tone Detection*; *Pre-Dial Delay*.

**Alarm Contact (E17)** See *Alarm Outputs*

**Alarm Codes** See *Report on Alarm*

### Alarm History

Hold-Down Key [S] will display (on the digital readout) all alarm conditions that have occurred. While holding down Key [S], note the number(s) displayed indicating the zone(s) violated. When the system is rearmed, the previous alarm history will stay memorized until automatically erased by a new alarm condition. Note that *Alarm History* will not display Fire, Fire Trouble, Ambush, or zones directed to Ambush.

**Alarm Outputs (Locations 181, 210-211; 224-225; Terminals 23, 24; NTO Lug E15; Alarm Contact Lug E17; Jumper A)**

### No Bell Output on Fire (Diode D5)

The MA1008LK has a common Burglary/Fire voltage output at Terminals 23 and 24 or normally open Dry Contacts at Terminal 23 and Lug E17 if Jumper A is cut (see *Wiring Diagram*). Steady bell and pulsing bell outputs for Burglary and Fire, respectively, may be obtained by programming (see Table 4).

For independent Fire and Burglary outputs, cut D5 and use Fire Lug E9 for Fire and Terminal 23 for Burglary. Use a relay on Lug E9 (see *Fire Lug*) with normally-open contacts that connect Alarm Contact E17 to the bell (+) on closure (leave Jumper A intact). See Fig. 3.

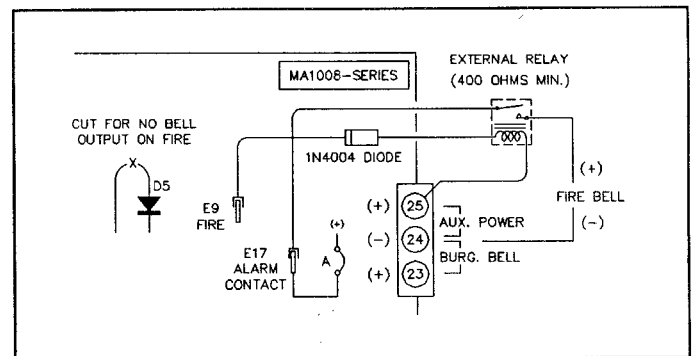

**Fig. 3. Independent fire and burglary outputs.**

Table 4 summarizes wiring and programming for signaling an alarm in typical installations. Refer to *Time Selection*

Output	Wiring	Output Locations	Timeout Locations	Remarks
Steady Bell*	Bell on 23 (+) & 24 (-)	210, 211	224, 225	—
Pulsing Fire Output	Bell on 23 (+) & 24 (-)	—	228, 229	Program "1" in Location 181
Alarm Contact	Bell on E17 & 24	210, 211	224, 225	—
Dry Contacts	23 (COM) & E17 (N/O)	210, 211	224, 225	Cut Jumper A
Untimed Output (NTO)	E15 (-) & 25 (+)	096-099	—	< 300mA for strobes, etc. See <i>NTO</i> .

\*In UL installations, see *Time Selection* for timeout requirements.

**Table 4. Alarm Outputs**

for timeout durations.

### Ambush Code (Locations 236, 237)

A 1- or 2-digit code that is entered by the user prior to disarming to access the Ambush Zone, causing a silent report to be sent to a central station. Thus, should a user be forced to disarm by an assailant, he can silently signal an emergency while appearing to be merely disarming the system. The Arm/Disarm Code must be entered less than 10 seconds after the Ambush Code for an ambush report to be transmitted. The Ambush Zone is a "report-only" zone; it will automatically report when programmed to report on alarm.

To program the ambush feature,

1. Program Ambush to *Report on Alarm* (enter a "2" in Location 168).
2. Enter 1 or 2 digits as the Ambush Code in Locations 236-237.
3. Enter an Ambush-Zone alarm report code in Locations 018-019.

Inform the user what the Ambush Code is, and that his arm/disarm code must be entered less than 10 seconds after the Ambush Code for an ambush report to be sent.

Also see *Panic Zone*.

### Anti-Jam Time

If the communicator does not detect a dial tone within 12 seconds, the *Anti-Jam* feature will be activated. That is, the communicator will go off-line for a 16-second anti-jam interval in order to free the telephone circuit from incoming calls, then make another 12-second attempt at dial-tone detection. If still unsuccessful, the communicator will again go off-line for 16 seconds, then proceed to dial anyway.

To test the *Anti-Jam* feature, call the alarm phone line from a different phone line, then activate an alarm. The incoming call should be disconnected by the control panel.

### Arm Lug (Lug E4)

Lug E4 (ARM) will go to approximately 1Vdc when the system is armed. This lug may be used for auxiliary equipment. For use, refer to the instructions furnished with the peripheral device. Also see *Sounder Output On Lug E4*.

### Audible Test on Arming (Location 180)

To test the alarm circuit each time the system is armed, add a "1" to Location 180. The alarm is then activated briefly about 8 seconds after the panel is armed. If the alarm does not sound, the device may be defective.

### Auto-Reset (Locations 180; 200, 201)

If a zone signals an alarm and is selected for *Auto-Reset*, it will automatically rearm itself soon after the alarm condition is removed. *Auto-Reset* may be delayed to occur after the timeout period by programming a "2" in Location 180.

Zones 1 through 6 that are not programmed for *Auto-Reset* will not be capable of signalling another alarm until (a) the cause of the alarm has been removed and (b) the panel is disarmed.

Also see *Swinger Shutdown*.

### Auto-Reset After Alarm Timeout See *Auto-Reset*

### Auto-Bypass Zone See *Remove Auto-Bypass*

### Backup Reporting (Location 178)

When *Backup Reporting* is selected and the com-

municator does not reach the first telephone number after two attempts, seven attempts will be made to reach the second telephone number. Enter Subscriber Identification Numbers for Telephone 2 (Locations 132-143) and other information required for Telephone 2 (Locations 144-163). If *Double Reporting* is selected with *Backup Reporting*, all reports sent to the first telephone number will also be transmitted to the second telephone number. However, if the first transmission fails, two reports will be sent to Telephone 2 (*Double Reporting*).

**Note:** Subscriber Identification Numbers for both Telephones 1 and 2 must be entered, even if they are the same.

### Battery

12Vdc standby power source in the control panel to provide backup protection in the event of a power loss. The RBAT4 (4AH) and RBAT6 (6AH) are available as options. Note that the battery is an integral part of the system. It must be installed, even if ac power is present.

### Burglary Output See *Alarm Outputs*

### Callback Telephone Number (Locations 270-285; PROM Page-1 Locations 014-029)

Number of Rings (Location 269; PROM Page-1 Location 013)

Enter the *Callback Telephone Number* in Locations 270-285 (PROM Page-1 Locations 014-029). This will instruct the MA1008LKDL to call back the PCI2000 as a security check prior to downloading when using the callback method. Program the *Callback Telephone Number* as any other telephone number. (Remember that a "D" or an "E" must be programmed before the telephone number — see *Telephone Numbers*).

The MA1008LKDL will initiate the callback after waiting 15 rings, unless programmed otherwise. To change the number of rings before callback, enter the desired number of rings (3 minimum, 15 maximum) in Location 269.

### Chime Zone (Location 088-089)

Chime On with Group Bypass See *Group Bypass Display Chime Zones* (Location 081)

This annunciator feature may be programmed for any zone to sound at the keypad while disarmed when the zone goes into trouble. Hold down Key [5] until the function beep sounds to enable or disable the Chime. Chime duration is programmable (Locations 230, 231) in units of 1/4 seconds. See *Time Selection*. Also see *Never-Arm Zone*.

**Note:** A "1" in Location 230 will prevent the sounder from coming on.

When a "4" is programmed in Location 081 (*Display Chime Zones*), the Chime-Zone number will be displayed for the duration of the programmed chime time, or for as long as the zone is tripped, whichever is greater. Also see *Chime On with Group Bypass*.

### Closing Report (*Select User(s) Closing*) (Location 174)

Force Arm Report (Locations 179; 038-039)

Status Report (Locations 179; 000-029; 038-039)

Include Manual Bypass in Force-Arm/Status Report (Location 183)

On arming, the communicator can transmit a closing code for each user, a Force-Arm Code, and a Status Report that identifies the problem zone to the central station. Note that Subscriber Identification Numbers (Locations 108-



111; 140-143) and Closing Codes (Locations 030-037) must be entered for any closing report. Program closing report (*Select User(s) Closing*, Location 174) to report each time the panel is armed. Each of up to four users may have his own Closing Code (Locations 030-037).

Select Force Arm Report ("2" in Location 179) to report only when arming with an auto-bypassed zone. This transmission will consist of a Closing Code followed by a Force-Arm Code. Select both closing report and Force Arm to always send a closing report, and a Force Arm report only if one or more zones were auto-bypassed. Also see *Priority Zone with Bypass*.

Select Status Report ("4" in Location 179) to send a Force Arm report followed by a Status Report that identifies the auto-bypassed zone(s). The second Alarm-Code location is usually used for this purpose. If this location is vacant, the first location will be used.

To include manual bypasses in a Force Arm/Status Report, program a "4" in Location 183. (Either Force Arm or Status Report must also be programmed.)

Following is an example of a typical Force-Arm/Status Report.

*Example.* A burglar breaks into a commercial establishment during the night, breaking the window foil. The Alarm Subscriber Identification Number is "123"; the Alarm Code is "1" (Burglary Zone 1); the Opening/Closing Subscriber Identification Number is "456"; the Force-Arm Code is "F"; the Closing Code for User 1 is "C". The communicator will send the following report to the central station (single-digit data format):

1231 - Sent when alarm occurs.

456B - Opening; User returned and inspected damage.

456C - Closing; User rearmed.

456F - Force Arm.

FFF1 - Zone status at time of closing: Window foil still broken. Zone 1 auto-bypasses; repair required.

**Control-Panel Restore** See *Restore Report*

**Data Format** (Locations 113, 145)

Consult the central station to find out which of the following formats to use.

**Extended Format.** Extended-format reporting allows the communicator to transmit an extra digit to the central station. This extra digit is generally used to report the user or the zone on which the event occurred.

*Example.* An installation uses the following programmed transmission information: Subscriber Identification Number is "678"; a Closing Report is selected for User 3; Extended Format Closing Code is "C3" (Closing, User 3). If User 3 closes, the communicator will transmit:

678C - Subscriber "678" has closed.

CCC3 - Closing, User 3.

Extended Format may be used with most central-station receivers. Most receivers capable of recognizing multiple reporting will also recognize Extended Format. The central station will indicate the event codes to be programmed. Extended Format does not require any programming in Locations 113 and 145. To use Extended Format, follow Steps 2 through 5 of *Two-Digit Event-Code Format* later in this section.

**Single-Digit Event Code Format.** If the receiver cannot

accept extended reporting,

1. Program a "1" in Location 113 (and 145 for a second telephone number, if used). See *Double Reporting* and *Backup Reporting*.
2. Enter the first digit for any Alarm/Trouble Code, Restore Code and Opening/Closing Codes.

**Note:** If it is desired to have a Single-Digit Event Code for one telephone number and Extended Format for the other, program both digits for all event codes. Use the first digit to indicate the alarm type and the second digit to indicate the zone. The telephone number with a "1" in Location 113 (or 145) will transmit only the first digit. The other telephone number will use both digits. (Single-Digit Format will ignore the second digit of the event code.)

**Two-Digit Event Code Format.** Some central-station receivers require that a two-digit code be sent in each report.

*Example.* In a certain installation, the Alarm Subscriber Number is "123"; a burglary alarm occurs on Zone 1 (Alarm Code "31"). The communicator will send "12331".

To use Two-Digit Event Code Format,

1. Program a "2" in Location 113 (145 for a second telephone number, if used). See *Double Reporting* and *Backup Reporting*.
2. Enter an Alarm Code (Locations 000-029) for each zone or condition to report on alarm (see *Report on Alarm*) or for a Force-Arm/Status Report as follows:
  - a. Enter the first digit of the Alarm Code. (This digit may be used to indicate alarm type.)
  - b. Enter the second digit of the Alarm Code. (This digit may be used to indicate the zone.)
3. Repeat Step 2 to enter Restore Codes (Locations 040-069) for each zone selected for *Control-Panel Restore* or *Zone Restore* (see *Restore Report*).
4. If Opening Report or Opening Report After Alarm is selected, enter a two-digit Opening Code for each user (Locations 070-077). See *Opening Report*; *Opening Report After Alarm*.
5. If Closing Report is selected, enter a two-digit Closing Code (Locations 030-037) for each user. If a Force Arm or Force-Arm/Status Report is selected, also enter a two-digit Force-Arm Code (Locations 038, 039).

**Note:** *Single-Digit Format* will override *Two-Digit Format* in Locations 113 and 145 if both are programmed.

**Sum-Check Format.** Sum Check is a sophisticated data format used to enhance the speed and check the accuracy of the received transmission. This format should be preferred whenever the central station is capable of receiving it.

After transmitting the Subscriber Identification Number and the event code, the communicator sends a verifying digit that is the sum of both. The receiver compares the verifying digit with the sum of the other two numbers to check transmission accuracy. To select *Sum Check*, program a "4" in Location 113 (or 145 for a second telephone number, if used).

**Day Zone** (Locations 186, 187)

**Disable Day-Zone Report** See *PIR Zone*

**Display Day Zones After Reset** (Location 078)

A Day Zone is a Burglary Zone programmed to cause visual and audible indication at the keypad if the loop has

an open condition only when disarmed. This feature may be used to warn of trouble during the day, when the control panel is not armed. If the Day Zone experiences a problem (a break in a window foil, for example), the green STATUS LED on the keypad will flash, the sounder will beep repeatedly, and the display will indicate the problem zone(s). Hold down Key [9] to silence the sounder and clear the display. Arm and disarm the panel to reset the Day Zone.

If a "1" is programmed in Location 078 (*Display Day Zones After Reset*), the Day-Zone number(s) will continue to display after the sounder is silenced until the condition is corrected, and the Day Zone will auto-reset without the need to arm/disarm.

**Note:** For high security Day-Zone supervision, also program *Disable Fault Find* (enabling Fault Find will disable Day-Zone supervision).

Also see *Watch On with Group Bypass*.

#### **Dealer Program Code (Locations 244-249)**

This code is required to enter the Dealer Program Mode. The default Dealer Program Code is 4,5,6,7,8,9, however this code must be changed to preserve system security. Reprogram the 3- to 6-digit Dealer Program Code starting in Location 244.

**Note:** (1) The Dealer Program Code must not start with the same numbers as the User Program Code. (2) This code also serves as your *Download Security Code*.

#### **Dial-Tone Detection (Locations 116, 148)**

At least one *Dial-Tone Detection* entry is usually required for each telephone number used to ensure that a dial tone is present before the communicator dials.

When an "E" is programmed before the first digit of an outside telephone number, the communicator dial-tone detection circuit is set to detect the standard 440Hz dial tone. The "E" is generally entered in Location 116 for Telephone 1 and Location 148 for Telephone 2, if used.

It may be necessary to program at least one 4-second *Pre-Dial Delay* before a *Dial-Tone Detection* "E". With certain nonstandard exchanges, *Pre-Dial-Delay* "D"s may be used without a *Dial-Detection* "E". (See *Access Number for Outside Line; Pre-Dial Delay*.)

#### **Direct Keypad Panic to Ambush See Panic Zone**

#### **Disable Bell Test (Location 182)**

Program an "8" in Location 182 to prevent unauthorized persons from sounding the bell.

#### **Disable Callback-Method Download (Location 080)**

Data may be remotely downloaded to an MA1008LKDL using Napco Quickloader™ software and interface if the correct download security code is known. Program this feature to prevent unauthorized downloading to an unattended panel.

#### **Disable Day-Zone Report See PIR Zone**

#### **Disable Display Bypass (Location 081)**

This feature disables Hold-Down Function 2 (*Display Bypass*) while armed for added security.

#### **Disable Fault Find (Location 182)**

When the Fault-Find mode is accessed (Hold-Down Key [7]), two things occur: (a) the loop response of all zones is preset to 7mS (fastest loop response), and (b) securing a

zone in trouble will cause the sounder to beep for about 2 seconds. This set of conditions aids both installer and user. The installer, tapping and poking at suspect points, can easily locate swingers by listening for the beep. Similarly, the user can confirm the repair of a zone in trouble by listening for the beep and thus eliminate the need of returning to the keypad to visually check after each attempt.

Hold down Reset Key [9] to restore normal operation. Arming the system successfully will automatically cancel the Fault-Find mode.

Program a "1" in Location 182 to prevent unauthorized use of the Fault-Find mode.

#### **Disable Function-6 Download (Location 080)**

Program an "8" in Location 080 to prevent manual remote downloading using Function 6 at the panel. See *Manual Download*.

#### **Display Any Bypass (Location 183)**

Hold-Down Function 2 (*Display Bypass*) normally displays manually-bypassed zones only. When *Display Any Bypass* is selected and a zone is auto-bypassed, the yellow BYPASS LED will light, and Hold-Down Function 2 will display Auto-Bypassed Zones and Priority Bypassed Zones as well.

#### **Display Chime Zones See Chime Zone**

#### **Display Day Zones After Reset See Day Zone**

#### **Double Reporting (Location 178)**

When *Double Reporting* is selected, only information that is successfully sent to Telephone 1 will be sent to Telephone 2 as well.

To program *Double Reporting*, enter an "8" in Location 178. Enter Subscriber Identification Numbers for Telephone 2 (Locations 132-143) and related information required for Telephone 2 (Locations 144-163).

If *Backup Reporting* is selected with *Double Reporting*, reports sent to the first telephone number will also be transmitted to the second telephone number. However, if the first transmission fails, two reports will be sent to Telephone 2.

*Split Reporting* will override *Double Reporting* if both are programmed.

**Note:** Subscriber Identification Numbers for both Telephones 1 and 2 must be entered, even if they are the same.

#### **"E" Lugs**

E3 – See *Ground-Start Module, GSM-400*

E4 – See *Arm Lug*; also see *Sounder Output on Lug E4*

E9 – See *Fire Lug*

E15 – See *NTO Lug*

E17 – See *Alarm Outputs*

#### **Enable Communicator-Confidence Test (Location 182)**

Program a "4" in Location 182 to enable the Communicator-Confidence Test. This feature checks the telephone line for the presence of a dial tone only in those systems that are programmed to communicate with a central station.

**Note:** Do not arm and disarm the panel just before making this test.

Hold down Key [6] until the sounder starts to pulse. If the

line is okay, the pulsing will stop, otherwise a steady tone will sound (check phone lines). To silence the sounder, hold down Reset Key [9].

#### **Enable Download with Answering Machine (Location 082)**

To permit downloading to a telephone with an answering machine, program a "1" in Location 082. After one ring, the panel will listen for the modem tone produced by the PCI2000. If the tone is recognized, the panel will go into line seizure and establish connection with the PCI2000, if security codes match.

#### **Enable Keypad Panic See *Panic Zone***

#### **Enable Keypad Sounder on Alarm (Locations 164-165)**

Programmable for Zones 1-6 and Keypad Panic. When tripped, a steady tone will sound at the keypad until the panel is disarmed.

#### **Enable Keypad Tactile Beep (Location 181)**

When a "4" is added to Location 181, the sounder will beep momentarily with each press of a button. For RP1000LCD keypads: cut the keypad tactile-beep jumper to prevent a double beep from sounding.

#### **Exit/Entry Delay (Locations 218-223)**

Permits exit and entry through the Exit/Entry Zone(s) (see Locations 202-205) after the system is armed without setting off an immediate alarm. Exit delay allows the user to leave the premises after the panel has been armed. Entry delay allows the user time to enter and disarm the panel. Upon entering, the keypad sounder will emit a steady tone to remind the user to disarm.

Two individually programmable entry delays are provided to accommodate different entry zones (one exit delay is provided for all). If two or more Exit/Entry Zones are entered in succession, the delay programmed for the last Exit/Entry Zone entered will take precedence over all others.

Exit-Delay time (Locations 218-219) and Entry-Delay time (Locations 220-223) may each be programmed for up to 255 seconds (4¼ minutes). See *Time Selection*. If delay times are not programmed, exit delay will be 60 seconds; entry delay will be 30 seconds. (In UL installations, Exit-Delay time may not exceed 60 seconds; Entry-Delay time may not exceed 45 seconds.)

Entry delay may be cancelled by holding down Key [4] (*Instant Protection*) prior to or after arming, however it will be automatically reinstated upon disarming.

#### **Exit/Entry Follower (Locations 206, 207)**

A zone programmed as an *Exit/Entry Follower* will ignore detection during the exit delay, and only during entry delay if the Exit/Entry Zone is entered first. Thus, detection devices (passive infrared detectors, for example) along the path between the keypad and the exit/entry door will not signal an alarm during exit/entry delay under normal conditions. However, if a device in the Exit/Entry Follower Zone detects a violation when the exit/entry door has not first been entered, there will be no entry delay and the Exit/Entry Follower Zone will go into an instant alarm.

If the panel is armed with the entry delays cancelled (*Instant Protection*), any violation on the Exit/Entry Zone or the Exit/Entry Follower Zone will cause an immediate alarm.

#### **Extended Format See *Data Format***

#### **Failure to Communicate on NTO Lug See *NTO Lug***

#### **Fault Find See *Disable Fault Find***

#### **Fire Lug (Lug E9)**

Lug E9 (FIRE) will go to about 1Vdc when a fire alarm is tripped. E9 may be used to trip an LW-900 Long-Range Wireless Interface. Or, a relay (400 ohms minimum) may be connected between E9 and Terminal 25 (+ AUX. POWER) if a diode is wired in series (cathode to E9; anode to relay coil). Also see *Alarm Outputs*.

#### **Fire Zone (Terminals 7 & 9)**

The Fire Zone is indicated by the red FIRE/TROUBLE keypad LED. Normally-open devices are connected across Terminals 7 and 9, in parallel with the 2200-ohm end-of-line resistor (see *Wiring Diagram*). A short across the Fire Zone will cause a fire alarm: the red LED will light and the the sounder will pulse; an open circuit (trouble) will cause a blinking red LED and a pulsing sounder after a 10-second delay. The sounder may be silenced using Reset Key [9]. The LED will go off within 30 seconds after reset if the alarm or trouble is cleared. Even if the Fire Zone is not used, the 2200-ohm end-of-line resistor is still required across Terminals 7 and 9.

If the Fire Zone is selected to *Report on Alarm* (Location 168) or to *Restore* (Location 172), the Alarm Codes in Locations 016-017 and the Restore Codes in Locations 056-057 will be sent. Trouble and Restore Trouble on the Fire Zone are reported in Locations 020-021 and 060-061, respectively. To reset Fire, program a "2" in Location 181 (see *Reset Fire*).

#### **Force-Arm Report See *Closing Report***

#### **Force-Arm/Status Report See *Closing Report***

#### **Ground-Start Module, GSM-400 (Lug E3)**

If the dial tone is not continuously active, Ground-Start Module Model GSM-400 will be required at Lug E3 to establish the dial tone. For installation, refer to the instructions furnished with the GSM-400.

#### **Group Bypass (Location 196, 197)**

#### **Chime On with Group Bypass (Location 081)**

*Group Bypass* removes a programmed group of zones from the system. Group bypassing is often used to deactivate some or all interior zones simultaneously so that the user may move freely throughout the premises but still be protected from intrusion through armed perimeter zones.

Group bypassing is accomplished by pressing Key [S] *twice*. When the panel is subsequently disarmed, all bypassed zones will revert to non-bypassed zones.

When group bypassing is selected, the yellow BYPASS LED on the keypad will light. The zones bypassed may be confirmed by holding down Key [2] (*Display Bypass*) until the function beep sounds and all zones have displayed.

When a "1" is entered in Location 081 (*Watch On with Group Bypass*), all Day Zones will be activated simultaneously (*Watch Mode*) when *Group Bypass* is activated. See *Watch On with Group Bypass*.

When a "2" is entered in Location 081 (*Chime On with Group Bypass*), the Chime Mode will be enabled for all programmed zones when *Group Bypass* is activated. Note that (a) *Group Bypass* need not be programmed for any zone for this feature to operate; (b) if a zone is programmed

as a Chime Zone, it may not be programmed for *Group Bypass*; and (c) if this feature is programmed, Hold-Down Function 5 (*Chime On/Off*) is disabled. Also see *Chime Zone*.

**Include Manual Bypass in Force-Arm/Status See Closing Report**

**Jumper A See Alarm Outputs**

**Keypad Panic (K/P) See Panic Zone**

**Line-Reversal Module, M278**

The Line-Reversal Module allows the control panel to be monitored by a central station through leased lines. On alarm, the module reverses normal line-voltage polarity. For details, refer to the instructions furnished with the module.

**Loop Response (Locations 214-217)**

Loop response is the amount of time that a normally-closed circuit must remain open, or a normally-open circuit must remain closed, to trigger an alarm. The slower the loop response, the more immune the system will be to intermittents ("swingers"). Selectable loop-response times are:

**750mS (.75 sec.):** The slowest loop-response time, recommended for use with magnetic contacts, window foil, etc. Unless programmed otherwise, loop-response time will be 750mS (milliseconds) for all zones.

**50mS (.05 sec.):** Used for momentary panic buttons and area-protection devices, such as photoelectric eyes, passive infrared sensors, floor mats, etc.

**7mS (.007 sec.):** An extremely fast loop response used primarily for window bugs.

**Low Battery (Location 169, 173)**

A low-battery alarm will signal when the battery terminal voltage drops to 11.2V. A low-battery condition may report to a central station by programming a "4" in Location 169.

**Never Arm (Locations 090-091)**

A zone programmed as *Never-Arm* cannot go into alarm. When tripped, it will display at the keypad when Hold-Down Function 3 (*Display Status*) is selected. A chime will sound at the keypad while armed or disarmed if Chime is programmed for that zone and enabled. (The display will also indicate the zone if *Display Chime* is programmed.) This feature is suggested for use as a garage-door or driveway monitor or similar application.

**No Ac See Ac-Failure Reporting**

**No Bell Output on Fire See Alarm Outputs**

**No End-of-Line Resistor (Locations 086-087)**

Program for any normally-closed zone that is not wired with an end-of-line resistor.

**No Opening Report After Alarm on Zone 6 (Location 183)**

If *Opening Report After Alarm* is selected and a TM900 Test Timer is installed, wire the TM900 to Zone 6 and program a "2" in Location 183. Also see *Opening Report After Alarm*.

**NTO (No Timed Output) Lug (Lug E15; Locations 096-099)**

**Failure to Communicate on NTO Lug (Location 078)**

Lug E15 is an untimed output, programmable for any

zone (Group 1 or Group 2). When tripped, the NTO Lug will go low. This output may be used for strobes (do not exceed 300mA), or to trip an LW-900 Long-Range Wireless Interface. If *Failure to Communicate on NTO Lug* is programmed ("2" in Location 078), Lug E15 will go low after the communicator makes 9 unsuccessful attempts to communicate. A relay (400 ohms minimum) may be connected between E15 and Terminal 25 (+ AUX. POWER) if a diode is inserted in series (cathode to E15; anode to relay coil). Also see *Abort Delay; Remote Status LED on NTO Lug*.

**Number of Rings See Callback Telephone Number**

**Opening & Closing Codes See Opening Report; Closing Report**

**Opening Report (Select User(s) Opening) (Location 176)**  
**Opening Report After Alarm (Location 179)**

Opening and closing reports are generally used in commercial installations. On disarming, the communicator can send an opening code for each user (*Select User(s) Opening*), or it may transmit only when the panel is disarmed after an alarm has occurred (*Opening Report After Alarm*). Note that Subscriber Identification Numbers (Locations 108-111; 140-143) and Opening Codes (Locations 070-077) must be entered for either opening report.

Program *Select User(s) Opening* (Location 176) to report each time the panel is disarmed. Each of up to four users may have his own Opening Code (Locations 070-077). If selecting *Opening Report*, do not select *Opening Report After Alarm*.

Program *Opening Report After Alarm* ("1" in Location 179) to report only when disarming after an alarm. This feature may be used by the central station to verify that the subscriber has responded to the alarm and disarmed the panel. If *Opening Report After Alarm* is selected, do not select *Opening Report*.

**Panic Zone**

**Direct Keypad Panic to Ambush (Location 080)**

**Enable Keypad Panic (Location 182)**

To enable Panic from the keypad (K/P on Programming Sheet), program a "2" in Location 182. The Panic Zone is tripped by simultaneously pressing Keys [\*] and [#] and may be programmed to send a silent alarm to a central station, activate an audible alarm, or both. Keypad Panic may be disabled at individual keypads by cutting a jumper on the keypad circuit board.

Remote momentary pushbutton panic switches (normally open) are connected across the two white wires on the keypad (RP854 or RP1054D only). In UL systems, remote panic buttons must be located in the same room as the keypad.

For silent panic, program a "1" in Location 080. This will direct Keypad Panic to the Ambush Zone. (Keypad panic will report using the Ambush Code.)

**PIR Zone (Locations 092, 093)**

**Sensor Watch® (Locations 094-095)**

**Disable Day-Zone Report (Location 079)**

**Power-Up Delay**

Program for any zone containing a PIR or Double-Tech® sensor, floor mats, door contacts, etc. Upon powering up the control panel, a 3-4 minute delay on these zones allows sensors to stabilize. For power-up delay only, do not program *Sensor-Watch Time* (Locations 094-095, see *Time*

*Selection*). Power-up delay may be cancelled by holding down Reset Key [9] until the function beep sounds.

If no trip is detected within the programmed Sensor-Watch time, a Day-Zone trouble will be transmitted to the central station, if programmed to report ("8" in Location 168). There is no audible indication at the keypad.

Program *Sensor Watch* in Locations 094-095. Select a value according to the expected activity within the coverage area while *disarmed*. In calculating the Sensor Watch time, note that only the disarmed hours (the time between armed periods) are added. In moderate traffic areas, a Sensor Watch time of perhaps 15 hours may be appropriate, whereas in remote areas, a time of 60 hours or more may be in order. Sensor Watch time should be calculated for the PIR Zone with the *least* amount of traffic. However, if no activity is expected on a zone (in an attic, for example) that zone should not be programmed as a PIR Zone. (If Locations 094-095 are left blank, PIR Zones will still be delayed on power-up, but they will not be monitored for activity.)

If this feature is selected and any other zones are programmed as Day Zones, a "2" may be programmed in Location 079 (*Disable Day-Zone Report*) to inhibit Day-Zone trouble reports. A Day-Zone condition will still display at the keypad, but a trouble report at the central station will now indicate a PIR-Zone trouble.

**Power Up in Last State (Location 180)**

When a "4" is programmed into Location 180, the control panel will return in its last state (armed or disarmed) when ac is restored after a lengthy power failure (and the battery is dead).

**Pre-Dial Delay (Locations 114, 146)**

A *Pre-Dial Delay* may be used whenever a delay is required before dialing. It is usually required to program *Dial-Tone Detection*, which causes the communicator to wait for a dial tone before dialing (see *Dial-Tone Detection*). Certain telephone exchanges send a nonstandard dial tone that the communicator may not be able to detect. With these nonstandard exchanges, it is possible to program *Pre-Dial Delay* rather than *Dial-Tone Detection*. This will cause the communicator to wait for a predetermined time before dialing rather than look for a nonstandard dial tone.

Contact the telephone-equipment supplier to find out how long a delay is required before dialing. Select *Pre-Dial Delay*

**FOR TECHNICAL ASSISTANCE,  
SALES, OR REPAIRS, CALL TOLL  
FREE:**

**(800) 645-9445**

by programming one "D" for each 4-second delay required. Enter *Pre-Dial Delay* "D"s starting in Location 114 for Telephone 1. If Telephone 2 is used, enter *Pre-Dial Delay* "D"s starting in Location 146. See *Backup Reporting*; *Double Reporting*; *Split Reporting*. Also see *Access Number for Outside Line*.

**Priority Zone (Locations 190, 191)**

A zone that will prevent arming if in trouble. If an attempt is made to arm, the sounder will emit a steady tone and a "P" will be displayed. The priority condition may be silenced by disarming. Any zone may be selected as a *Priority Zone*. A zone in trouble that is neither a *Priority Zone* nor an *Auto-Bypass Zone* will cause an alarm on arming.

**Priority Zone with Bypass (Locations 188, 189)**

A *Priority Zone* that will permit arming if the priority condition is bypassed by pressing Reset Key [9], then entering a User Code. The zone will auto-bypass and, if status is reported, the condition can be communicated to a central station.

Any zone not selected as a *Priority Zone* may be programmed as a *Priority Zone with Bypass*. When programming a zone as *Priority with Bypass*, do not program *Remove Auto-Bypass*. Also see *Display Any Bypass*.

**Pulsing Bell Output See Alarm Outputs**

**Receiver Format (Locations 112, 144)**

The communicator can transmit to any standard central-station receiver. A receiver format must be programmed for each telephone number used, but a different format may be assigned to each.

Refer to *Double Reporting* and *Backup Reporting* to determine if Telephone 2 will be programmed. Call the central station for each telephone number to check the type of receiver in use. From Table 5, enter the receiver format for each phone number.

Entry	Receiver Format	Data Freq. (Hz)	Duty Cycle (On/Off)	Inter-digit Time
blank	Ademco, Silent Knight <i>Slow</i>	1900	60/40mS	600mS
1	Sescoa, Vertex, DCI, Franklin	1800	30/20	800
2	Radionics <i>Fast</i>	1800	13/12	400
3	Silent Knight <i>Fast</i>	1900	40/30	560
4	Radionics, DCI, Franklin <i>Slow</i>	1800	60/40	600
5	Universal Hi-Speed			
6	Reserved			
7	Radionics BFSK			
8	Add "8" for 2300Hz Handshake; do not add if 1400Hz Handshake.			

**Table 5. Receiver Formats.**

Program the receiver-format entry in Location 112 for Telephone 1 and Location 144 for Telephone 2, if used.

**Relay Output See Alarm Outputs**

### Remote Status LED on NTO Lug (Location 082)

When a "2" is programmed in Location 082, a remote Status LED connected to the NTO Lug will go on when the lug is low, giving the same indication as the keypad STATUS LED. In this application, do not use the NTO Lug as an output. Connect the LED cathode to the lug through a 560-ohm resistor, and the anode to +12V AUX. POWER (Terminal 25).

### Remove Auto-Bypass (Locations 192, 193)

All zones are preprogrammed for Auto-Bypass, and will be bypassed if in trouble when arming. A momentary beep will sound at the keypad to warn that the system has been armed without the protection of the auto-bypassed zone. (Note that the exit/entry door must be closed before arming, otherwise the Exit/Entry Zone will be auto-bypassed.) Auto-bypassing may be removed from any Zone 1-6 by programming.

**Note:** If auto-bypass is removed from a zone in trouble that is not programmed for Priority arming (Locations 190, 191), that zone will cause an alarm on arming. If selecting *Priority Zone with Bypass*, do not select *Remove Auto-Bypass*.

For UL installations, non-24-Hour Zones with auto-bypass (*Remove Auto-Bypass* not programmed) must be programmed for *Priority Zone with Bypass*. If an attempt is made to arm with these zones in trouble, the sounder will come on, a "P" will be displayed, and the panel will not arm (enter a valid arm/disarm code to silence the sounder and clear the display). To arm, hold down Reset Key [9] for about 2 seconds, then enter the arm/disarm code.

### Report on Alarm (Locations 156-169)

Violation of a zone selected to report on alarm will cause the communicator to transmit the code selected for that zone to the central station. Enter Alarm Codes (Locations 000-029) for each zone to report on alarm, even if identical codes are used for different zones.

### Reset Fire (Location 181)

If detection devices used require removal of dc voltage to reset, program a "2" in Location 181 and wire the device power leads to Terminals 9 (+) and 7 (-) for two-wire devices, or Terminals 9 (+) and 8 (-) for four-wire devices (see *Wiring Diagram*). Holding down Reset Key [9] until the

sounder beeps will momentarily remove power from Terminal 9.

### Reset Test Timer on Report See *Test Timer*

### Restore Report

#### Restore, Control-Panel (Locations 170-173)

#### Restore, Zone (Locations 184, 185)

If programming *Zone Restore*, *Control-Panel Restore* must be programmed as well. When selecting a Restore Report, (a) Subscriber Alarm/Restore Identification Numbers must be programmed for Telephone 1 (Locations 100-107) and Telephone 2 (Locations 132-139), if used; and (b) Restore Codes (Locations 040-069) must be entered for each zone selected to report a restore.

The communicator can transmit a report to the central station when a zone or the control panel is restored. To select the time of reporting, refer to Table 6.

### Select User(s) Closing See *Closing Report*

### Select User(s) Opening See *Opening Report*

### Selective Bypass (Locations 194, 195)

Removal of one particular zone from the system. Any or all Zones 1-6 programmed for *Selective Bypass* may be removed from the system, but each must be removed separately.

Selectively bypass a zone by pressing Bypass Key [S] followed by the zone number. The next time the panel is disarmed, all bypassed zones will automatically revert to non-bypassed zones.

When one or more zones is bypassed, the yellow BYPASS LED on the keypad will light. The zones bypassed may be confirmed by holding down Key [2] (*Display Bypass*) until the function beep sounds; with the key depressed, the bypassed zones will be displayed.

### Sensor Watch™ See *PIR Zone; Time Selection*

### Service Code See *User 5 Service Code*

### Single-Digit Format See *Data Format*

### Smoke Detectors (Terminals 7 (-) & 9 (+))

Connect smoke detectors as shown on the *Wiring Diagram*. Note that Terminals 7 and 9 may be used for the Fire Zone only. Up to 10 compatible two-wire smoke detec-

Program:	for Control-Panel Restore to be sent:	and for Zone Restore to be sent:	
Instant <i>Auto-Reset</i> (Locations 200, 201)	When (a) zone is repaired; or (b) control panel is disarmed	When zone is repaired, whether panel is armed or disarmed	
<i>Auto-Reset After Alarm Timeout</i> (Locations 200, 201; "2" in Location 180)	When (a) resets (alarm times out & zone repaired); or (b) when panel is disarmed.	When zone resets (alarm times out & zone is repaired) whether panel is armed or disarmed.	
		(See Note 2) <b>Zone Repaired with Panel</b>	
		<b>Armed</b>	<b>Disarmed</b>
No <i>Auto-Reset</i>	When panel is disarmed (regardless of zone condition)	When panel is disarmed	When panel is armed & disarmed again

Table 6. Restore Reports

### Note:

- 24-Hour Zone restores are sent as shown under Zone Restore.
- It is recommended that Zone-Restore Zones or 24-Hour Zones be programmed with Auto Reset or Priority Zone to prevent accidental auto-bypassing of a latched zone.

tors may be "daisy-chained" together. Subtract smoke-detector alarm current from auxiliary standby current. See *COMPATIBLE UL-LISTED DEVICES*.

**Note:** If they are of the self-resetting type, power 4-wire smokes from the Constant Auxiliary Voltage Output at Terminal 25 instead of Terminal 9.

#### **Sounder Output on Lug E4 (Location 180)**

When an "8" is programmed in Location 180, Lug E4 will go low whenever the keypad sounder is activated. This feature disables Lug E4 for use as an Arm Lug (see *Arm Lug*).

#### **Split Reporting (Location 179)**

*Split Reporting* causes all reports except Openings, Closings, and Test Timer to be sent to Telephone No. 1, while Openings, Closings, and Test Timer report to Telephone No. 2. (*Split Reporting* overrides *Backup Reporting* or *Double Reporting* if either combination is programmed.) Enter Subscriber IDs (Locations 132-143) and other information (Locations 144-163) required for Telephone 2. Note that Subscriber ID Numbers for Telephones 1 and 2 must be entered, even if they are the same.

**Status Report** See *Closing Report*

#### **Subscriber Identification Numbers (Locations 100-111; 132-143)**

Different *Subscriber Identification Numbers* (account numbers) may be used by the central station to distinguish Alarm and Restore Reports (Locations 100-107) from Opening and Closing Reports (Locations 108-111). Similarly, different numbers may be used to distinguish Alarm/Restore Reports for Group-1 Zones (Zones 1-6) from Group-2 Zones (Fire to Low Battery). Both groups must be programmed, even if both use the same number. See *Report on Alarm; Restore Report; Opening Report; Closing Report*.

Furthermore, if a second telephone is used, different Subscriber Identification Numbers may be required for Alarm/Restore Reports (Locations 132-139) and Opening/Closing Reports (Locations 140-143). As above, both groups must be programmed, even if both use the same number. See *Double Reporting; Backup Reporting*.

#### **Note:**

1. If the central station cannot accept two-digit or extended event codes, the Alarm and Restore Codes may be the same as the Opening and Closing Codes; or, the Alarm/Restore Codes may be the same for Groups 1 and 2 if the respective Subscriber Identification Numbers are different.
2. Starting at the left-most location, enter at least 3 digits for each Subscriber Identification Number, even if the first two are zeros. A fourth digit is available for those receivers capable of recognizing 4-digit subscriber codes.

**Sum Check** See *Data Format*

#### **Swinger Shutdown (Locations 084-085)**

When programmed, Zones 1 through 6 with *Auto-Reset* will only reset twice (3 alarms) until rearmed in order to prevent "swingers" (intermittents) from causing repeated false alarms. (Do not program for UL installations.) See *Auto-Reset*.

#### **Telephone Numbers (Locations 117-131; 149-163)**

To report to a central station, Telephone Number 1 (Locations 117-131) must be programmed. Telephone Number 2 (Locations 149-163) is programmed if *Backup Reporting*, *Split Reporting* or *Double Reporting* is selected.

Telephone Number 1 will be preceded by at least one *Dial-Tone Detection* entry ("E" in Location 116) or *Pre-Dial Delay* entry ("D" in Location 114) to ensure that the communicator detects a dial tone or waits a reasonable time to access a telephone line before dialing. (See *Dial-Tone Detection; Pre-Dial Delay*.) Furthermore, private telephone systems may require a separate *Dial-Tone Detection* or *Pre-Dial Delay* digit, followed by an *Access Number* (Location 115) to obtain an outside line. (See *Access Number for Outside Line*.)

It should be noted here that Telephone Number 1 need not actually start in Location 117 nor end in Location 131, as extra locations have been provided to allow for additional prefix digits, if required. What is important is that Telephone Number 1, with its associated *Pre-Dial Delay*, *Access Number*, and *Dial-Tone Detection*, be wholly contained within Locations 114-131, and that they be in their proper sequence. It may, in fact, be advantageous to leave one or two blank locations before entering the telephone number to allow for the unexpected (an additional *Pre-Dial Delay*, for example). The above applies to *Telephone Number 2* (Locations 149-163) and the *Callback Telephone Number* (Locations 270-285; PROM Page-1 Locations 014-029) as well.

**Note:** An "F" in any location will be ignored by the communicator when dialing.

#### **Test Timer (Locations 024, 025; 169)**

##### **Reset Test Timer on Report (Location 181)**

When a "1" is programmed into Location 169, a daily test report will be transmitted to the central station from the time the panel is powered up. The respective Alarm Code is programmed into Locations 024, 025.

By entering an "8" in Location 181, the timer will be programmed to send a daily test only if there has been no other report. (Note that this, or the above, is required in UL installations.) Thus, if one normally reports an opening every weekday morning, for example, this feature may be utilized to maintain reporting continuity on weekends.

##### **Test-Timer Offset (Locations 250, 251)**

If Test Timer is programmed, the test timer will report immediately upon power-up, and every 24 hours thereafter. To delay the timer reporting time up to 24 hours from power-up time, program Locations 250 and 251 in hours (see *Time Selection*). (If these locations are left blank, the test timer will report immediately upon power-up.)

##### **Timeout (Locations 224-231)**

Specifies the length of time that an alarm, alert, or delay will remain active. Abort-Delay time and Burglary timeout must be programmed, or the feature will not activate. See *Time Selection*.

**Note:** In installations governed by California Fire Marshal regulations, do not program a timeout for fire alarms.

##### **Time Selection** Also see *Programming Sheet*

The times shown in Table 8 are programmable. The Time Selector Chart on the Programming Sheet shows example times only, in seconds or minutes. In reality, any time up to

those shown in Table 8 may be programmed. Note that each time is programmed in two locations. The first location has a time factor of 1, the second a time factor of 16.

<b>1st box</b>	<b>2nd box</b>
tx1	tx16

<b>Time (t)</b>	0	1	2	3	4	5	6	7	8	9	10	11	12	13	14	15
<b>Entry</b>	*	1	2	3	4	5	6	7	8	9	0	B	C	D	E	F

\*Blank. Note: If both programming locations are left blank, refer to Table 8 Notes for feature timeout.

**Table 7. Program entries for unit times.**

To select a time up to 15 seconds, 15 minutes, or 15 quarter-seconds (3.75 seconds), program the respective entry into the first box only; do not program the second box. To select a time greater than 15 seconds, 15 minutes, or 15 quarter-seconds, program both boxes as follows:

1. For the feature selected, choose an appropriate time in units shown (all seconds, minutes, or quarter-seconds -- not minutes and seconds, etc.).
2. Divide the time chosen by 16. Enter the quotient in the 2nd Box and the remainder in the 1st Box.
3. Check entries by adding the contents of the 1st Box to 16 times the contents of the 2nd Box. (Remember that a "zero" entry represents "10".)

*Example 1. Program Entry Delay 1 for 1½ minutes.*

1. *Entry Delay 1* (Locations 220, 221) is in units of seconds, thus delay time is 90 seconds.
2. Divide by 16:  $90/16 = 5$  (quotient) + 10 (remainder). Enter the *quotient* in the 2nd Box and the *remainder* in the 1st Box:

<b>220</b>	<b>221</b>
0	5

remainder (0 for "10")                      quotient

3. Check entries (remember, a "0" entry = "10"):  $10 + 16(5) = 90$ .

*Example 2. Program the sounder to sound a "Chime" for 4 seconds.*

1. Chime time duration (Locations 230, 231) is in units of quarter-seconds, thus chime duration is 16 quarter-seconds.
2. Divide by 16:  $16/16 = 1$  (quotient) + 0 (remainder). Enter the *quotient* in the 2nd Box and the *remainder* (blank entry for "0") in the 1st Box:

<b>230</b>	<b>231</b>
	1

remainder (blank for "0")                      quotient

3. Check entries (remember, a blank entry = "0"):  $0 + 16(1) = 16$ .

<b>Time</b>	<b>Locations</b>	<b>Units</b>	<b>Max. Time</b>
Sensor-Watch Time (See Note 1)	094, 095	hr	255 hr
Abort Delay (See Note 1)	232, 233	sec	4 min, 15 sec (255 sec)
Exit Delay (See Note 2)	218, 219	sec	4 min, 15 sec (255 sec)
Entry Delay 1 (See Note 2)	220, 221	sec	4 min, 15 sec (255 sec)
Entry Delay 2 (See Note 2)	222, 223	sec	4 min, 15 sec (255 sec)
Burglary Timeout (See Notes 1 & 3)	224, 225	min	4 hr, 15 min (255 min)
Fire-Zone Timeout	228, 229	min	Untimed (See Note 4)
Chime Duration	230, 231	¼-sec	Untimed (See Note 4)
Timer Offset	250, 251	hr	23 hr (See Note 5)

**Table 8. Programmable times and timeouts.**

**Notes:**

1. If both locations are left blank, this feature will not activate (timeout = 0).
2. If both locations are left blank, Exit Delay = 60 sec.; Entry Delay = 30 sec.
3. Timeout must be at least 4 minutes in UL installations.
4. If both locations are left blank, this feature will remain active until system is disarmed. (Chime may be reset using Key [9]; however if a time is programmed, Chime cannot be reset and must time out.) If both locations are programmed "F", maximum time = 4 hours, 15 minutes (255 minutes); or 63.75 seconds (255 quarter-seconds) for Chime Duration.
5. If left blank and Test Timer is selected, will report immediately on power-up.
6. In installations governed by California Fire Marshal regulations, do not program a timeout for fire alarms.

**TouchTone® Dialing (Location 178)**

**TouchTone® with Rotary Backup (Location 178)**

Select *TouchTone Dialing* only when the subscriber has TouchTone service. TouchTone dialing is faster than rotary dialing, but not always as reliable.

For the communicator to use TouchTone on all dial attempts, add a "1" to Location 178. To use TouchTone on the first attempt with subsequent rotary dial attempts, add a "2" to Location 178. *TouchTone Dialing* will override *TouchTone with Rotary Backup* if both are selected. Note that if *Backup Reporting* is also selected, the communicator will use rotary dial to reach Telephone 2.

**Trouble**

An abnormal zone condition (a break in a normally-closed loop; a short on a normally-open loop; or either on an end-of-line-resistor supervised loop) while disarmed.

Trouble on a Burglary Zone will be indicated by a sounder beep upon arming (does not apply to selective- or group-bypassed zones). If auto-bypass has been removed from a Burglary Zone, that zone will go into alarm on arming.



Note that if the zone is Exit/Entry, it will go into alarm after exit-delay and entry-delay times have elapsed.

Trouble (open circuit) on a Day Zone (normally closed) is indicated by a flashing green STATUS LED and a beeping sounder; the digital readout will display the troubled zone(s). Keypad indications are reset by Key [9].

A Fire-Zone trouble is indicated by the red FIRE/TROUBLE LED and by the sounder. An open circuit or short to ground on Fire Power (Terminal 9) or Aux. Power (Terminal 25) will cause a flashing LED and a pulsing sounder after a 10-second delay. (A short across the Fire-Zone EOL resistor will cause an alarm condition: steady LED and pulsing sounder.) Reset Key [9] will silence the sounder; the LED will go out within 30 seconds if the cause of the trouble has been removed.

**Two-Digit Format** See *Data Format*

**Untimed Output** See *NTO (No Timed Output) Lug*

**User Program Code** (Locations 238-243)

A code, entered to access the User Program Mode, that allows an authority to program User Codes and the Service Code (see *GETTING UP AND RUNNING – Programming User Codes*). The default User Program Code is 1,2,3,4,5,6, however this code must be changed to preserve system security. Enter the 3- to 6-digit User Program Code starting in Location 238.

**Note:** The Dealer Program Code must not start with the same numbers as the User Program Code.

**User 5 Arm Only** (Location 078)

**User 5 Report as User 1** (Location 078)

**User 5 Service Code** (Location 079)

To restrict User Code 5 as an "arm-only" code (for single-digit easy arming), program a "4" in Location 078. (Do not program *User 5 Service Code*.) Note that if a single-digit arm-only code is programmed, the hold-down function for that digit is disabled.

The Service Code, if programmed, provides reduced access to the control panel for those with limited authority. Operation is similar to that of a regular Arm/Disarm Code,

except that the Service Code is disabled at times. When active, it may be used to arm or disarm as many times as necessary.

The Service Code is controlled by User 1. Whenever User 1 enters his code, the Service Code is deactivated. To activate, merely arm using the Service Code. The Service Code can always be used to arm.

To enable User Code 5 as a Service Code, program a "1" in Location 079. For the Service Code to report, it must report as User 1 ("8" in Location 078).

**Watch On with Group Bypass** (Location 081)

The Watch Mode activates all Day Zones simultaneously by group bypassing (pressing Key [S] twice), even if no zones are selected for *Group Bypass* (see *Group Bypass*). When a "1" is entered in Location 081, the Watch Mode will be enabled when *Group Bypass* is activated. Note that (a) *Group Bypass* need not be programmed for any zone for this feature to operate; (b) if a zone is programmed as a *Day Zone*, it may not be programmed for *Group Bypass*; and (c) *Chime On with Group Bypass* should not be programmed.

**Zone Restore** See *Restore Report*

Normally, Control-Panel Restore is programmed for a zone to send a restore report to the central station. The report will be sent when either the zone is repaired or the panel is disarmed. If the restore report is to be sent only when the zone is repaired, *Zone Restore* should be selected (also program *Control-Panel Restore*). It is recommended that *Auto Reset* and *Priority Zone* or *Priority Zone with Bypass* also be selected for proper operation. See *Restore Report*.

**24-Hour Protection** (Locations 198, 199)

A zone that provides protection at all times, whether or not the system is armed. Neither the green STATUS nor the red ARMED/ALARM LED will indicate the condition of a zone programmed for *24-Hour Protection*, however an alarm condition will be recorded by Alarm History (see *Alarm History*).

## NOTES

## INDEX

A			
Abort Delay	15		
also see <i>Time Selection</i>	23–24		
Accessories, see <i>Optional Accessories</i>	4		
Account Numbers,			
see <i>Subscriber Identification Numbers</i>	23		
Ac-Failure Reporting	15		
Access Number for Outside Line	15		
Alarm Contact (Lug E17), see <i>Alarm Outputs</i>	15		
Alarm Codes, see <i>Report on Alarm</i>	22		
Alarm History (Key [S])	15		
Alarm Outputs	3, 15		
also see <i>Time Selection</i>	23–24		
Alarm Reset	8		
Alarm Timeout, see <i>Timeout</i>	23		
Ambush Code	16		
Anti-Jam Time	16		
Arm Lug (Lug E4)	16		
Arm/Disarm Codes,			
see <i>Programming User Codes</i>	7		
Arm-Only Code, see <i>User 5 Arm Only</i>	25		
Arming/Disarming	8		
also see <i>Ac Failure Reporting</i>	15		
Audible Test on Arming	16		
Auto-Reset	16		
Auto-Reset After Alarm Timeout, see <i>Auto-Reset</i>	16		
Auto-Bypass Zone, see <i>Remove Auto-Bypass</i>	22		
B			
Backup Reporting	16		
also see <i>Double Reporting</i>	18		
Battery	16		
Bell Output, see <i>Alarm Outputs</i>	15		
Burglary Output, see <i>Alarm Outputs</i>	15		
Bypass,			
Group	19		
Selective	22		
C			
Callback-Method Download,			
see <i>Callback Telephone Number</i>	16		
also see <i>Disable Callback-Method Download</i>	18		
Callback Telephone Number	16		
also see <i>Telephone Numbers</i>	23		
Central-Station Reporting	7		
Chime (Key [5])	16		
also see <i>Time Selection</i>	23–24		
Chime On with Group Bypass, see <i>Group Bypass</i>	19		
Closing Codes,			
see <i>Closing Report</i>	16–17		
Closing Report	16–17		
Communicator-Confidence Test (Key [6],			
see <i>Enable Communicator-Confidence Test</i>	18–19		
Conditional-Opening Report,			
see <i>Opening Report After Alarm</i>	20		
Control-Panel Restore Report,			
see <i>Restore, Control Panel</i>	22		
D			
Data Format	17		
Day Zone	17		
Trouble, see <i>Trouble</i>	24–25		
also see <i>Watch On with Group Bypass</i>	25		
Dealer Program Code	9, 11, 18		
Default Program	7		
Dial Delay, see <i>Pre-Dial Delay</i>	21		
Dial-Tone Detection	18		
Direct Keypad Panic to Ambush, see <i>Panic Zone</i>	20		
Disable Bell Test	18		
Disable Callback-Method Download	18		
Disable Day-Zone Report, see <i>PIR Zone</i>	20–21		
Disable Display Bypass	18		
Disable Fault Find	18		
also see <i>Day Zone</i>	17–18		
Disable Function-6 Download	18		
Display	3		
Display Any Bypass	18		
Display Chime Zones, see <i>Chime Zone</i>	16		
Display Day Zones After Reset, see <i>Day Zone</i>	17–18		
Display Bypass (Key [2]) see <i>Display Any Bypass</i>	18		
also see <i>Disable Display Bypass</i>	18		
Double Reporting	18		
also see <i>Backup Reporting</i>	16		
and <i>Split Reporting</i>	23		
Download Security Code, see <i>Dealer Program Code</i>	18		
Downloading From a Computer	11		
Callback Method	11		
also see <i>Callback Telephone Number</i>	16		
Function-6 (Manual Download) Method	11		
E			
"E" Lugs			
E3, see <i>Ground-Start Module, GSM-400</i>	19		
E4, see <i>Arm Lug</i>	16		
also see <i>Sounder Output on Lug E4</i>	23		
E9, see <i>Fire Lug</i>	19		
E15, see <i>NTO Lug</i>	20		
also see <i>Alarm Outputs</i>	15		
E17 (Alarm Contact), see <i>Alarm Outputs</i>	15		
Easy Arming, see <i>User 5 Arm Only</i>	25		
Enable Communicator-Confidence Test	18–19		
Enable Download with Answering Machine	19		
Enable Keypad Panic, see <i>Panic Zone</i>	20		
Enable Keypad Sounder on Alarm	19		
Enable Keypad Tactile Beep	19		
Entry Delay	19		
also see <i>Time Selection</i>	23–24		
Equipment Supplied	4		
Exit Delay	19		

also see <i>Time Selection</i>	23-24
Exit/Entry Follower	19
Exit/Entry Zone, see <i>Exit/Entry Delay</i>	19
Extended Format, see <i>Data Format</i>	17

## F

Failure to Communicate on NTO Lug, see <i>NTO Lug</i>	20
Fault Find (Key [7]) see <i>Disable Fault Find</i>	18
Features	3-4
Fire	
Installation, Typical	6
LED (FIRE/TROUBLE) see <i>Trouble</i>	24-25
Lug (Lug E9)	19
Trouble, see <i>Trouble</i>	25
Zone	19
also see <i>Alarm Outputs</i>	15
Reset Fire	22
Time Selection	23-24
Force Arm Report, see <i>Closing Report</i>	16-17
Function-6 (Manual Download)	11

## G

Glossary	15-25
Ground-Start Module, GSM-400 (Lug E3)	19
Grounding	6
Group Bypass	19

## H

Hold-Down Functions	3
---------------------	---

## I

Include Manual Bypass in Force-Arm/Status Report, see <i>Closing Report</i>	16-17
Installation	6

## J

Jumper A, see <i>Alarm Outputs</i>	15
------------------------------------	----

## K

Keypad,	
Functions	3-4
Operation	9-10
Wiring	6
Keypad Panic see <i>Panic Zone</i>	20
Keypad Programming,	
Dealer	9-10
User	7-8

## L

Line-Reversal Module, M278	20
Loop Response	20
Low Battery	20

## M

Manual Download (Key [6])	11
Mounting, Control Panel	6

## N

Never-Arm	20
No Ac, see <i>Ac-Failure Reporting</i>	15
No Bell Output on Fire, see <i>Alarm Outputs</i>	15
No End-of-Line Resistor	20
No Opening Report After Alarm on Zone 6	20
NTO Lug (Lug E15)	20
Number of Rings, see <i>Callback Telephone Number</i>	16

## O

Opening Codes, see <i>Opening Report</i>	20
Opening Report	20
Opening Report After Alarm	20
Optional Equipment	4
Ordering Information	4
Outputs, see <i>Alarm Outputs</i>	15

## P

Panic Zone	20
PIR Zone	20-21
also see <i>Time Selection</i>	23-24
Power-Up Delay	20-21
Power Up in Last State	21
Power-Up Sequence	7
Pre-Dial Delay	21
Priority Zone	21
Priority Zone with Bypass	21
Program (Key [8])	7-8, 9
Program Code	
Dealer	9, 18
User	7, 25
Programming	9-11
Examples	9, 10
Keypad	7, 9
PROM	10, 11
Record Sheets	10, 12-14
Steps	10
User Codes	7
PROM (DD499),	
Programming	10, 11
Transferring Memory From	11
Pulsing Fire Output, see <i>Alarm Outputs</i>	15

## R

Receiver Format	21
Remote Status LED on NTO Lug	22
Remove Auto-Bypass	22
Report on Alarm	22
also see <i>Programming Example 2</i>	10
Reset (Key [9])	3
Reset, Alarm	8
Reset Fire	22
Reset Test Timer on Report, see <i>Test Timer</i>	23
Restore Report	22
Restore Codes, see <i>Restore Report</i>	22
RJ31X Telephone Jack, see <i>Power-Up Sequence</i>	7

## S

Select User(s) Closing, see <i>Closing Report</i>	16-17
Select User(s) Opening, see <i>Opening Report</i>	20
Selective Bypass	22
Sensor Watch, see <i>PIR Zone</i>	20-21
also see <i>Time Selection</i>	23-24
Service Code, see <i>User 5 Service Code</i>	25
also see <i>Programming User Codes</i>	7
Single-Digit Event Code Format, see <i>Data Format</i>	17
Smoke Detectors	22-23
Sounder Indications	3-4
Sounder Output on Lug E4	23
Specifications	4
Split Reporting	23
also see <i>Double Reporting</i>	18
Status Report, see <i>Closing Report</i>	16-17
Strobes, see <i>NTO Lug</i>	20
Subscriber Identification Numbers	23
Subscriber PROM	10, 11
Sum-Check Format, see <i>Data Format</i>	17
Swinger Shutdown	23
System Troubles	8

## T

Tamper Switches	6
Telephone Cord, see <i>Power-Up Sequence</i>	7
Telephone Numbers	23
Test (Key [1])	3
also see <i>Audible Test on Arming</i>	16
Test Timer	23
Test-Timer Offset	23
Testing the System	8
Timeout	23

Time Selection	23-24
TouchTone Dialing	24
TouchTone with Rotary Backup	24
Trouble	24-25
Two-Digit Event Code Format, see <i>Data Format</i>	17

## U

UL	
Classification	4
Listed Devices, Compatible	5
Requirements, Summary of	5
Unconditional Closing Report, see <i>Closing Report</i>	16-17
Untimed Output, see <i>NTO Lug</i>	20
User Codes	7-8
User Keypad Programming	7
User Program Code	7, 25
User 5 Arm Only	25
User 5 Report as User 1	25
User 5 Service Code	25
also see <i>Programming User Codes</i>	7

## W

Watch Mode, see <i>Watch On with Group Bypass</i>	25
Watch On with Group Bypass	25
Wiring Diagram	30
Wiring Legend	31

## Z

Zone Restore	25
also see <i>Restore Report</i>	22
24-Hour Protection	25

# 5. WIRING DIAGRAM

**NAPCO SECURITY SYSTEMS, INC.**  
**AMITYVILLE, N.Y. 11701**

This equipment should be installed in accordance with the National Fire Protection Association's Standard 74 (National Fire Protection Association, Batterypark Park, Quincy, MA 02289) and local codes. Printed information describing proper installation, operation, testing, maintenance, evacuation planning, and repair service is to be provided with this equipment. Refer to Operation and Installation Manual W445.

**PROM - LOADING SEQUENCE**

1. REMOVE ALL POWER
2. INSERT PROGRAMMED PROM
3. CONNECT AC POWER
4. ENTER DEALER PROGRAM MODE
5. WAIT 10 SECONDS
6. REMOVE PROM

**MAGNUM ALERT 1008LK/1008LKDL**  
**WIRING DIAGRAM**

REFER TO INSTALLATION INSTRUCTIONS W445

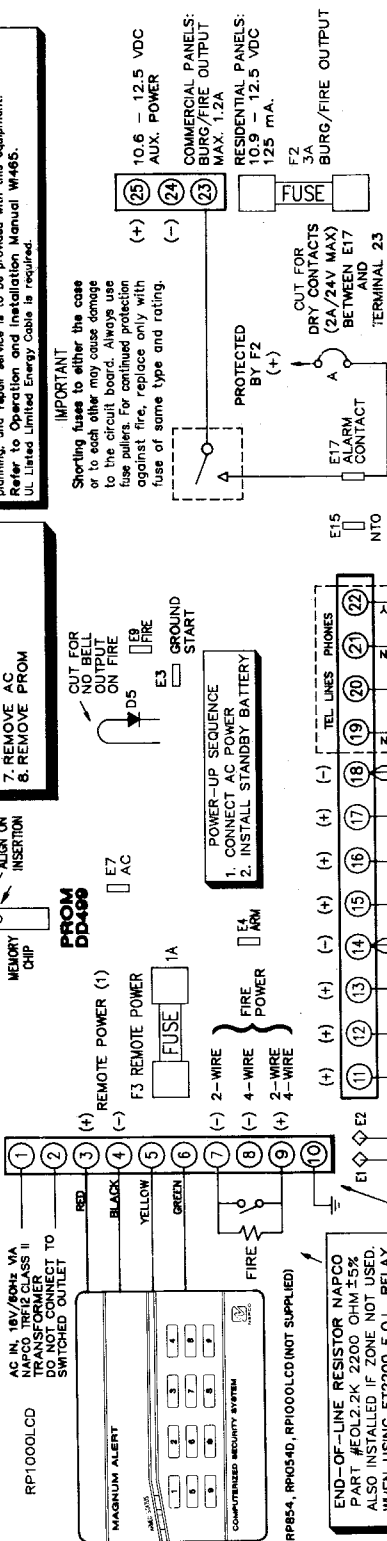

**WARNING:**  
**TO PREVENT RISK OF ELECTRIC SHOCK DISCONNECT TELEPHONE LINES PRIOR TO SERVICING.**

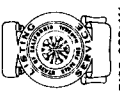

7185-982-111

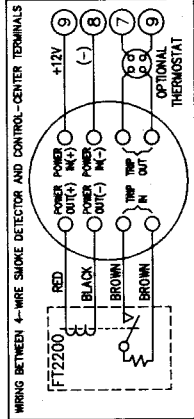
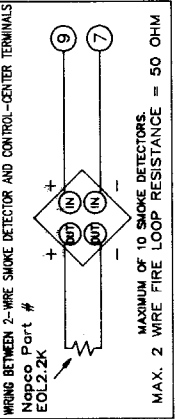

**IMPORTANT**  
 Shorting fuses to either the case or to each other may cause damage to the circuit board. Always use fuse pullers. For continued protection against fire, replace only with fuse of same type and rating.

**COMMERCIAL PANELS:**  
 BURGL/FIRE OUTPUT  
 MAX. 1.2A

**RESIDENTIAL PANELS:**  
 BURGL/FIRE OUTPUT  
 MAX. 125 mA.

**PROM DD499**  
 E7 AC  
 E4 ARM  
 E3 GROUND START  
 E2 NTO

**POWER-UP SEQUENCE**  
 1. CONNECT AC POWER  
 2. INSTALL STANDBY BATTERY

**END-OF-LINE RESISTOR NAPCO PART #EOL2.2K 2200 OHM ±5% ALSO INSTALLED IF ZONE NOT USED. WHEN USING FT2200 E.O.L. RELAY DO NOT INSTALL E.O.L. RESISTOR. SEE SMOKE DETECTOR DIAGRAM.**

**COLD WATER GROUND CONNECTION**  
 USE ONLY COLD-WATER PIPE ON BURGL GROUND ROD. USE AT LEAST #16 AWG WIRE.

**BATTERY STANDBY:**  
 4 HOURS AT 500mA  
 COMBINED STANDBY CURRENT  
 6 HOURS AT 350 mA.

**Connection of a fire alarm signal to a fire alarm headquarters or a central station should be made only with approval of the local authority having jurisdiction. The burglar alarm signal shall not be connected to a police emergency number.**

## WIRING LEGEND

**Instructions:** Should removal of the circuit board be necessary, use this wiring legend to relocate leads to their proper terminals. Enter wire identification number or color code in

the *Wire No./Color Code* column; wire function in the *Description* column (optional).

Terminal No.	Wire No./Color Code	Description
1		
2		
3		
4		
5		
6		
7		
8		
9		
10		
11		
12		
13		
14		
15		
16		
17		
18		
19		
20		
21		
22		
23		
24		
25		

# NAPCO LIMITED WARRANTY

**N**APCO SECURITY SYSTEMS, INC. (NAPCO) warrants its products to be free from manufacturing defects in materials and workmanship for fifteen months following the date of manufacture. NAPCO will, within said period, at its option, repair or replace any product failing to operate correctly without charge to the original purchaser or user.

This warranty shall not apply to any equipment, or any part thereof, which has been repaired by others, improperly installed, improperly used, abused, altered, damaged, subjected to acts of God, or on which any serial numbers have been altered, defaced or removed. Seller will not be responsible for any dismantling or reinstallation charges.

In case of defect, contact the security professional who installed and maintains your security system. NAPCO shall have no obligation under this warranty, or otherwise, if the product has been repaired by others, improperly installed, improperly used, abused, altered, damaged, subjected to accident, nuisance, flood, fire or acts of God, or on which any serial numbers have been altered, defaced or removed. NAPCO will not be responsible for any dismantling, reassembly or reinstallation charges.

In order to exercise the warranty, the product must be returned by the user or purchaser, shipping costs prepaid and insured to NAPCO. After repair or replacement, NAPCO assumes the cost of returning products under warranty.

*There are no warranties, express or implied, which extend beyond the description on the face hereof. There is no express or implied warranty of merchantability or a warranty of fitness for a particular purpose. Additionally, this warranty is in lieu of all other obligations or liabilities on the part of NAPCO.*

Any action for breach of warranty, including but not limited to any implied warranty of merchantability, must be brought within the six months following the end of the warranty period. In no case shall NAPCO be liable to anyone for any consequential or incidental damages for breach of this or any other warranty, express or implied, even if the loss or damage is caused by the seller's own negligence or fault.

*This warranty contains the entire warranty. It is the sole warranty and any prior agreements or representations, whether oral or written, are either merged herein or are expressly cancelled. NAPCO neither assumes, nor authorizes any other person purporting to act on its behalf to modify, to change, or to assume for it, any other warranty or liability concerning its products.*

In no event shall NAPCO be liable for an amount in

excess of NAPCO's original selling price of the product, for any loss or damage, whether direct, indirect, incidental, consequential, or otherwise arising out of any failure of the product. Seller's warranty, as hereinabove set forth, shall not be enlarged, diminished or affected by and no obligation or liability shall arise or grow out of Seller's rendering of technical advice or service in connection with Buyer's order of the goods furnished hereunder.

**NAPCO RECOMMENDS THAT THE ENTIRE SYSTEM BE COMPLETELY TESTED WEEKLY.**

**Warning:** Despite frequent testing, and due to, but not limited to, any or all of the following; criminal tampering, electrical or communications disruption, it is possible for the system to fail to perform as expected. NAPCO does not represent that the product/system may not be compromised or circumvented; or that the product or system will prevent any personal injury or property loss by burglary, robbery, fire or otherwise; nor that the product or system will in all cases provide adequate warning or protection. A properly installed and maintained alarm may only reduce risk of burglary, robbery, fire or otherwise but it is not insurance or a guarantee that these events will not occur. **CONSEQUENTLY, SELLER SHALL HAVE NO LIABILITY FOR ANY PERSONAL INJURY, PROPERTY DAMAGE, OR OTHER LOSS BASED ON A CLAIM THE PRODUCT FAILED TO GIVE WARNING.** Therefore, the installer should in turn advise the consumer to take any and all precautions for his or her safety including, but not limited to, fleeing the premises and calling police or fire department, in order to mitigate the possibilities of harm and/or damage.

NAPCO is not an insurer of either the property or safety of the user's family or employees, and limits its liability for any loss or damage including incidental or consequential damages to NAPCO's original selling price of the product regardless of the cause of such loss or damage. If the user wishes to protect itself to a greater extent, NAPCO will, at user's sole cost and expense, obtain an insurance policy to protect the user, supplemental to user's own policy, at a premium to be determined by NAPCO's insurer upon written notice from user by Certified Mail, Return Receipt Requested, to NAPCO's home office address, and upon payment of the annual premium cost by user.

Some states do not allow limitations on how long an implied Warranty lasts or do not allow the exclusion or limitation of incidental or consequential damages, or differentiate in their treatment of limitations of liability for ordinary or gross negligence, so the above limitations or exclusions may not apply to you. This Warranty gives you specific legal rights and you may also have other rights which vary from state to state.